

Recent advances on study of hadrosaurid dinosaurs in Heilongjiang (Amur) River area between China and Russia

Pascal Godefroit¹ , Pascaline Lauters¹ , Jimmy Van Itterbeeck² ,
Yuri L. Bolotsky³ , DONG Zhiming⁴ , JIN Liyong⁵ , WU Wenhao⁶ ,
Ivan Y. Bolotsky^{3 6} , HAI Shulin⁷ and YU Tingxiang⁷

1. Royal Belgian Institute of Natural Sciences , Department of Palaeontology , B - 1 000 Bruxelles , Belgium;
2. Afdeling Historische Geologie , Katholieke Universiteit Leuven , B - 3000 Leuven , Belgium;
3. Amur Natural History Museum , Institute of Geology and Nature Exploration FEB RAS , 675000 Blagoveschensk , Amurskaya Oblast' , Russia;
4. IVPP , Beijing 100044 / Research Center of Paleontology and Stratigraphy , Jilin University , Changchun 130026 , China;
5. Museum of Jilin University , Changchun 130026 , China;
6. Research Center for Paleontology and Stratigraphy , Jilin University , Changchun 130061 , China;
7. The Geological Museum of Heilongjiang , Harbin 150036 , China

Abstract: Four main dinosaur-bearing sites have been investigated in latest Cretaceous deposits from the Amur/Heilongjiang Region: Jiayin and Wulaga in China (Yuliangze Formation) , Blagoveschensk and Kundur in Russia (Udurchukan Formation) . More than 90% of the bones discovered in these localities belong to hollow-crested lambeosaurine hadrosaurids: *Charonosaurus jiyinensis* at Jiayin , *Amurosaurus riabinini* at Blagoveschensk , *Olorotitan arharensis* at Kundur , and *Sahaliyania elunchunorum* at Wulaga. Flat-headed hadrosaurine hadrosaurids are much less numerous , but appear well diversified as well: *Kerberosaurus manakini* at Blagoveschensk , *Wulagasaurus dongi* at Wulaga , and a new genus at Kundur. Theropods are represented by shed teeth and isolated bones; isolated scutes and teeth discovered at Kundur are tentatively attributed to nodosaurids. Palynological studies suggest that these sites are probably synchronous with the Lancian' vertebrate localities of western North America , which represent the youngest dinosaur faunas in this area. However , the latest Cretaceous dinosaur assemblages are completely different in the Amur/Heilongjiang region (lambeosaurines abundant , ceratopsids absent) and in western North America (ceratopsids abundant , lambeosaurines extremely rare or absent) . This probably reflects some kind of geographical barrier between both areas by Maastrichtian time rather than strong differences in palaeoecological conditions.

Key words: Heilongjiang Province; Amur Region; Late Cretaceous; dinosaurs; Hadrosauridae; palaeobiogeography

Introduction

The Hadrosauroidae , or duck-billed' dinosaurs ,

can be defined as those dinosaurs more closely related to *Parasaurolophus* than to *Iguanodon* (*sensu* Sereno , 1998) . They were very successful herbivorous dino-

saur during the closing stages of the Cretaceous. During the Campanian and the Maastrichtian , they were the primary constituents of many terrestrial vertebrate faunas. In western North America , hundreds of fragmentary or complete hadrosaurid specimens have been collected , including remains of eggs , embryos , hatchlings and juveniles. They were apparently spread almost world-wide: besides North America , fossils have also been discovered in Central America , South America , Europe , Asia (Horner *et al.* , 2004) and apparently even in Antarctica (Rich *et al.* , 1999) . The main reason for this evolutionary success was probably their very efficient plant-processing masticatory apparatus , characterised by an improved mobility of the upper jaw and by an elaborated dental battery well adapted for feeding on hard vegetation. Besides typical hadrosaurids , the hadrosauroid clade includes a number of less derived forms that were present in Laurasia from the late Early Cretaceous (You *et al.* , 2003) to the Maastrichtian. Hadrosauridae (sensu Sereno , 1998) includes members of the Hadrosaurinae and Lambeosaurinae and their most recent common ancestor. With the exception of Horner (1990 , 1992) , all the authors working on hadrosauroid phylogeny accept the monophyly of Hadrosauridae and , within this family , that of the Hadrosaurinae and Lambeosaurinae. However , even Horner has subsequently indicated his acceptance of the monophyly of Hadrosauridae (Horner *et al.* , 2004) . Flat-headed Hadrosaurinae are characterised , for example , by the development of depressed areas around the external nares and by the lateral expansion of their premaxillary beak. Some hadrosaurines , such as *Prosaurolophus* , *Saurolophus* , *Brachylophosaurus* and *Maiasaura* are characterised by the presence of a low , solid cranial crest , whereas others , such as *Edmontosaurus* , *Anatotitan* , or *Gryposaurus* , lack any kind of crest development. The lambeosaurines are characterised by an important diversity of hollow cranial crests. The nasal cavity is completely modified and extends into this hollow crest , forming a complex system of internal passages. With this hollow crest , it is postulated that

lambeosaurines could produce different kinds of trumpeting noises (Weishampel , 1981) . As different species are characterised by different shapes of crests , they produced different noises.



Fig. 1 Map of the Amur/Heilongjiang Region (modified from Kirillova , 2003) indicating the main dinosaur sites

Since the beginning of the 20th century , a great amount of hadrosaurid bones and partial skeletons have been discovered along both sides of the Amur-Heilongjiang River. Four localities were particularly productive (Fig. 1) : Longgushan (Jiayin) and Wulaga along the Chinese banks of the Amur-Heilongjiang River , Blagoveschensk and Kundur along the Russian side of the river. It is therefore quite surprising that the detailed study of these fossils only started very recently. In fact , these specimens have proved to be of fundamental importance for a better understanding of hadrosaurid palaeobiogeography and , especially , of dinosaur extinction patterns at the end of the Creta-

ceous. In this paper , we summarise the information available at present about latest Cretaceous dinosaurs from Heilongjiang Province and the Amur Region. Most data concern the hadrosaurids , which are by far the most abundant , the most diversified and the best-preserved dinosaurs discovered in this area.

Abbreviations: AEHM: Amur Natural History Museum , Blagoveschensk , Russia; CUST: Museum of Jilin University , Changchun , China; GMH: Geological Museum of Heilongjiang , Harbin , China.

Jiayin (Longgushan; N48° 51' 27. 6" / E130° 14' 37. 7")

History of the discoveries—*Mandschurosaurus amurensis* (Riabinin , 1925)

In 1902 , the Russian Colonel Manakin obtained a few fossil bones from Cossack fishermen; the bones were apparently found along the banks of the Amur River. Manakin believed that the fossils belonged to the famous Siberian mammoth and reported the discovery in the local journal *Priamourskie Vedomosti* . He deposited the bones in the local Museum of Khabarovsk. Also in 1902 , A. I. Gurov , Professor at Blagoveschensk , explored the banks of the Amur River and also discovered fossil bones. He reported his discovery on a map of the Amur River drawn in 1903 , mentioning that these fossils belonged to “antediluvian animals” . This map is currently housed in the Historical Museum at Blagoveschensk. The discovery spot is located in the vicinity of the village of Jiayin , in Heilongjiang Province , China.

Manakin’s and Gurov’s discoveries alerted the attention of Russian geologists to the Amur area. In 1914 , A. N. Krishtofovitsh , geologist at the Russian Geological Committee in St. Petersburg , discovered a large fragmentary bone in the Amur Region. On the returning to St. Petersburg , he showed the bone to his colleague A. N. Riabinin , who identified it as the proximal end of a dinosaurian tibia or fibula (Riabinin , 1914) . During the winter of 1915–1916 , another geologist at the Russian Geological Committee , W. P. Rengarten , went to the Amur Region and studied a geological section opened in the Belyie Kruchi’

(White Cliffs) , . . . on the right shore of the Amur River , some distance downstream from the mouth of Ayan , between the villages Kasatkino and Sagibovo’ (Riabinin , 1925 , fig. 1) . This place roughly corresponds to Gurov’s discovery spot. At the bottom of the cliff , Rengarten discovered dinosaur bones within a greenish conglomerate.

Following these preliminary researches , the Russian Geological Committee undertook two excavation campaigns during the summers of 1916 and 1917 under the direction of preparator N. P. Stepanov , and unearthed several bonebeds in the greenish conglomerate along the right side of the Amur River. Before the October 1917 Revolution , all finds , including the incomplete skeleton of a hadrosaurid dinosaur , were transported to the Museum of the Geological Committee to be prepared and studied.

The hadrosaurid skeleton was prepared by Stepanov between 1918 and 1923 and mounted under the supervision of Riabinin in 1924 (Fig. 2) . Riabinin (1925) gave a preliminary description of the skeleton and named it *Trachodon amurensis*. He subsequently described it in detail and attributed it to the new genus *Mandschurosaurus* (Riabinin , 1930a) , regarded as a member of the subfamily Hadrosaurinae.

In another paper , Riabinin (1930b) described fragmentary turtle bones from the same locality as *Aspideretes planicostatus* sp. nov. , isolated theropod teeth as *Albertosaurus periculosus* sp. nov. and the proximal end of a hadrosaurian left ischium as *Saurolophus Kryschtofovici* (sic) sp. nov. Because of the presence of the genera *Albertosaurus* and *Saurolophus* , he concluded that the age of the Belyie Kruchi fauna was similar to that of the Edmonton Formation in Canada. However , because of the very fragmentary state of preservation of the type material , *Saurolophus kryschtofovici* is unanimously regarded as a *nomen dubium* (see e. g. Maryńska and Osmólska , 1981; Horner et al. , 2004) . According to Molnar et al. (1990 , p. 190) , *Albertosaurus periculosus* might be a synonym of *Tarbosaurus bataar*. Nevertheless , the teeth illustrated by Riabinin (1930b , pl. 1 , Fig. 2) do not dis-



Fig. 2 Composite reconstruction of *Mandschurosaurus amurensis* (Riabinin , 1925) , displayed in the Centralny Geologicheskyy Muzey imeni akademika F. N. Chernishova (St Petersburg)

play any diagnostic characters and must consequently be regarded as a Tyrannosauridae indet.

Rozhdestvensky (1977) was very sceptical about the validity of *Mandschurosaurus amurensis* because of the scarcity of the material and the absence of diagnostic skull elements. Moreover , as admitted by Riabinin (1930a) himself , the type skeleton is probably reconstructed from several individuals. Young (1958) observed that the specimen is so much restored for mounting that the real characters are mostly difficult to see. Brett-Surman (1979) regarded *Mandschurosaurus amurensis* as a *nomen dubium* , because ‘there is not one single landmark or major morphological feature on any of the elements’. This opinion was subsequently followed by Maryańska and Osmólska (1981) and Horner *et al.* (2004) , and is retained herein.

Between 1975 and 1979 the Heilongjiang Provincial Museum (Harbin) undertook new excavations along the Chinese banks of the Amur River at Longgus-

han near Jiayin and discovered many new hadrosaurid and theropod fossils. Two partial specimens , labelled as *Mandschurosaurus amurensis* , were restored and exhibited in the Heilongjiang Provincial Museum. Unfortunately , one of the restored skeletons was completely destroyed during a fire. Yang *et al.* (1986) and Yang (1987) briefly described the material collected during these excavations. New material was also recovered from this area , in 1989 , by the Museum of Jilin University; one incomplete specimen , labelled as *Mandschurosaurus amurensis* , was restored for exhibition in the Geological Museum of that institution. In 1992 , the Geological Museum of Heilongjiang (Harbin) also started excavations along the Amur River , unearthing one large incomplete skeleton , displayed in that institution under the label *Mandschurosaurus magnus* , and also isolated hadrosaurid , theropod and turtle bones (Xing *et al.* , 1994) .

In 2002 , K. Johnson discovered a hadrosaurian footprint in the upper Yong’ancun Formation along the right bank of the Amur/Heilongjiang River in the vicinity of Jiayin. Dong *et al.* (2003) described it as *Jiayinosauropus johnsoni*.

Geological setting

The Jiayin dinosaur locality is situated along the cliffs on the right side of the Amur River (Fig. 3B) (Heilongjiang Province , China) , 8 km west of the town of Jiayin. Within these cliffs , also known as the Longgushan section , dinosaur-bearing sediments of the Yuliangze Formation are exposed. In order to preserve these dinosaur-bearing cliffs for future generations , the Chinese government is currently fortifying their base with a concrete wall (Fig. 3C) . The lithostratigraphic column presented here (Fig. 3A) was measured in a temporary exposure behind these walls during the summer of 2004.

The sediments of the Yuliangze Formation reflect an ancient fluvial environment with yellow coarse-grained channel deposits and green fine-grained floodplain deposits. Within these floodplain deposits several reddish-purple palaeosol horizons have been observed (Fig. 3D) . Some of the green fine-grained de-

posits also contain a considerable amount of coarser lithic clasts (1 mm–6 cm). It is within these diamict layers that most of the dinosaur bones have been

found. Several bone-bearing horizons have been excavated since the discovery of this site.

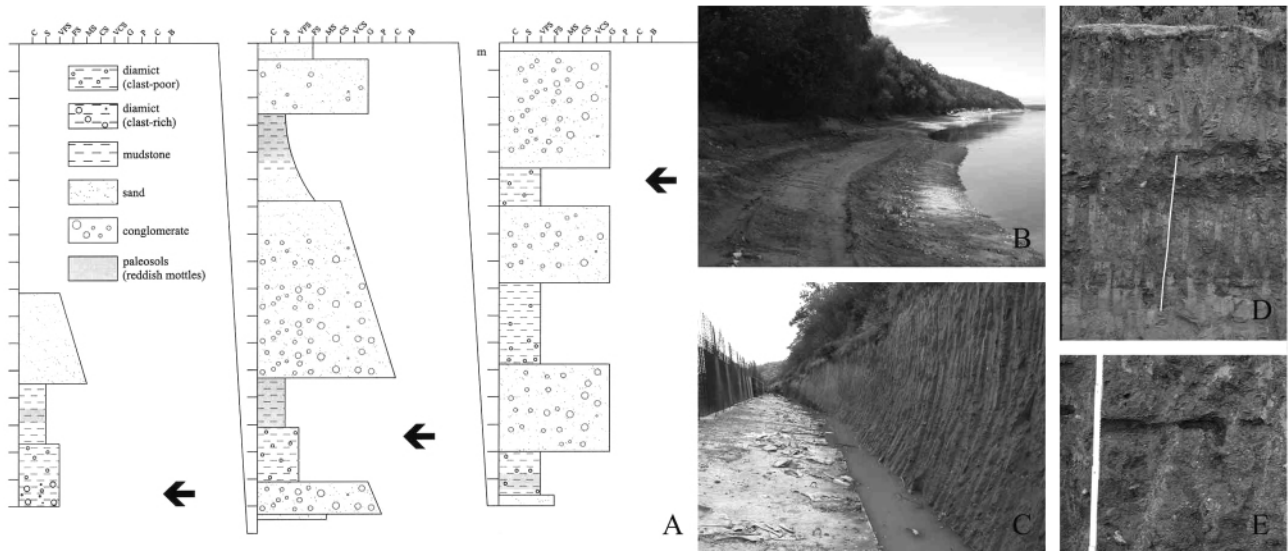

Fig. 3 A: lithostratigraphy of the Longgushan section (Jiayin , China) , black arrows indicate the excavated dinosaur-bearing layers. B: view on the Longgushan section along the right side of the Amur River. C: view on temporary outcrop behind concrete cliff protection. D: sediments of the Yuliangze Formation with reddish-purple palaeosol horizons. E: diamictite layer with black dinosaur bones

The lambeosaurine *Charonosaurus jiayinensis* Godefroit , Zan and Jin , 2000

Around 90% of the bones discovered at Jiayin/ Longgushan belong to lambeosaurine dinosaurs. The other vertebrate material consists of hadrosaurine , theropod , crocodyliform and turtle bones. Godefroit *et al.* (2000 , 2001) reviewed the hadrosaurid material discovered at the Longgushan locality and housed in the Museum of Jilin University (Changchun) and in the Geological Museum of Heilongjiang (Harbin) . They also checked the numerous fossils in the Heilongjiang Provincial Museum (Harbin) . They described the lambeosaurine *Charonosaurus jiayinensis* as the dominant hadrosaurid dinosaur from the Jiayin locality.

Holotype: CUST J-V1251-57 (Museum of Jilin University , Changchun) , a partial skull.

Locality and horizon: Longgushan (Jiayin) , Heilongjiang Province , China. Yuliangze Formation ,

Maastrichtian , Upper Cretaceous.

Diagnosis: Dorsal surface of parietal regularly rounded , without sagittal crest; lateral side of squamosal nearly completely covered by caudal ramus of postorbital; paroccipital and postcotyloid processes very low , extending only to the mid-height of foramen magnum; alar process of basisphenoid very prominent and symmetrical; caudal crest strongly developed on the humerus; forearm particularly elongated and slender: ratio total length / maximal width of the proximal head' > 6.3 for the ulna and > 6.6 for the radius; preacetabular process of ilium very long: ilium length / preacetabular length < 2.1.

Abridged description (Fig. 4) : *Charonosaurus jiayinensis* was a large ornithopod: the femora reach a length of 135 cm and are therefore longer than in any other known hadrosaurid except *Shantungosaurus giganteus*. The supratemporal fenestrae are proportionally short and wide. The dorsal surface of the frontal is highly modified to support the base of a hollow

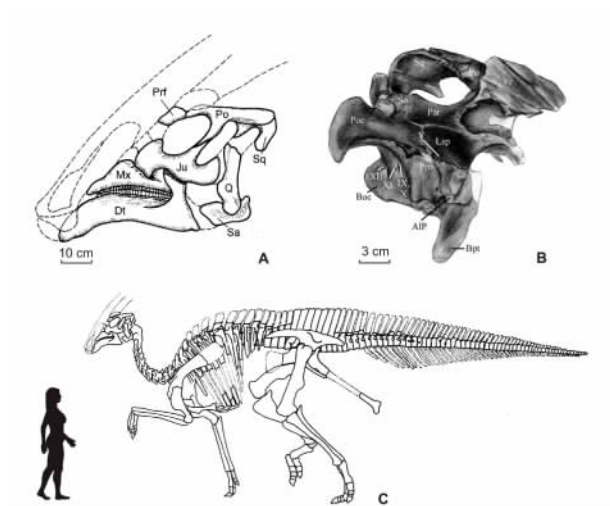

A: reconstruction of the skull in left lateral view. B: holotype CUST J-V1251-57 (back of the skull) in right lateral view. C: reconstruction of the whole skeleton. Abbreviations: AIP , alar process; Boc , basioccipital; Bpt , basipterygoid process; Dt , dentary; Fr , frontal; Ju , jugal; Lsp , laterosphenoid; Mx , maxilla; Par , parietal; Po , post-orbital; Poc , paroccipital process; Prf , prefrontal; Pro , prootic; Q , quadrate; Sa , surangular; So , supraoccipital; Sq , squamosal. V , X-XII: foramina for cranial nerves.

Fig. 4 *Charonosaurus jiaiyinensis* , from the Yuliangze Formation (Maastrichtian) of Jiayin (China)

crest: it forms a very broad and excavated platform , strongly inclined forwardly and ornamented by long and deep longitudinal grooves. The caudolateral part of the frontal projects dorsally and overhangs the rostral portion of the parietal and supratemporal fenestra. The rostradorsal surface of the postorbital also forms a thickened promontorium that participated in the base of the supracranial crest. The caudal ramus of the postorbital is long and broad , nearly completely covering the lateral side of the squamosal. The parietal is relatively short and does not extend caudally towards the occipital surface of the skull; its dorsal surface is smoothly convex and does not possess any trace of a sagittal crest. The lateral side of the squamosal is particularly elevated above the cotyloid cavity. The post-cotyloid process of the squamosal and the paroccipital process of the exoccipital are , on the other hand , shortened ventrally , extending only to the mid-height of the foramen magnum. The rostral process of the jugal is dorso-ventrally expanded and symmetrically rounded in lateral view. As in all Hadrosauridae , the

ectopterygoid ridge is strongly developed on the lateral side of the maxilla; unlike Hadrosaurinae , the dorsal process lies caudal to the mid-point of the maxilla. The quadrate closely resembles that of North American Hadrosauridae: a continuous elongated articular facet extends along the dorsal part of the quadratojugal notch , indicating that the paraquadratic foramen was absent , and its ventral head is dominated by a large hemispheric lateral condyle that articulated with the surangular component of the mandibular glenoid. As in other members of Hadrosauridae , the basioccipital neck supporting the occipital condyle is shortened , and the articular surface of the latter is perfectly vertical. The basipterygoid processes extend well below the level of the occipital condyle; above each basipterygoid process , the lateral side of the basisphenoid forms a large , symmetrical and well-detached alar process , formed by one rostral and one caudal wing. The supraoccipital bears a pair of prominent craniodorsal knobs , lodging into caudolateral depressions of the parietal. The robust dentary is strongly deflected rostrally , forming an angle of about 30 with the long axis of the bone. The dental battery of the dentary is formed by about 40 tooth rows in adult specimens; because the teeth are very high , each row is formed by only 2 or 3 teeth , with one to two functional ones. The diastema is very short in juveniles and more extended in larger individuals. Dentary teeth are very high , the largest dental crowns reaching 50 mm in height , with a height/length ratio >4; they bear a single sinuous vertical ridge. The sacrum is composed of 9 co-ossified vertebrae. The unusual features of the forelimb and pectoral girdle are essentially linked to the elongation of the forearm and to the concomitant development of a strong bicapital and tricapital musculature. The cranial head of the scapula bears , on its caudolateral side , a prominent buttress marking the insertion area of a powerful *M. triceps scapulae laterale externum*. The coracoid bears a prominent hook-like process pointing cranio-ventrally; even in juvenile specimens , its lateral side bears a very prominent knob for insertion of a very strong *M. biceps*. The humerus develops a prominent deltopectoral crest extending distal to the mid-point of the bone and a wide bicapital gutter on its cranial side; a caudal tricapital crest is developed in all specimens ,

but is particularly prominent in older individuals. Both the ulna and radius are very elongated and slender, with a total length/maximal width of the proximal head ratio >6.3 for the ulna and >6.6 for the radius. The preacetabular process of the ilium is longer than in other hadrosaurids (see Brett-Surman, 1989), with a ilium length / preacetabular length ratio <2.1 , but it is not very deflected ventrally; the antitrochanter is particularly prominent. The distal end of the ischium forms an expanded and footed knob. The prepubic blade is relatively short and high and abruptly expands cranially. The distal head of the fibula is greatly expanded and club-shaped. The cranial ascending process of the astragalus forms an equilateral triangle in cranial view.

Hadrosaurine remains from Jiayin

Several bones included in the *Mandschurosaurus amurensis* holotype skeleton (humerus, part of the mandibular material) undoubtedly belong to hadrosaurine hadrosaurids. Wu et al. (2011) also described a partial left dentary with dozens teeth from the Longgushan locality that clearly belong to hadrosaurinae, because it is characterized by the following synapomorphies: 5 teeth or more in each alveolus of the dentary and dentary marginal denticles reduced to small papillae along the dorsal half of the crown. Well developed secondary and tertiary ridges on the lingual side of the dentary crowns are unusual in hadrosaurids.

Blagoveschensk (N50° 16' 11.6"/E127° 28' 33.1")

History of the discoveries

Rozhdestvensky (1957) was the first to mention the presence of dinosaur fossils in the Russian part of the Amur Region: he collected isolated and rolled bones at Blagoveschensk and along the right bank of the Bureya River. But he misinterpreted the geological context of the discoveries, believing that the bones were reworked within latest Neogene or Quaternary deposits.

In 1981, Y. Bolotsky and the Amur Complex Integrated Research Institute (Amur KNII) of the Far Eastern Branch of the Russian Academy of Sciences discovered a large dinosaur bonebed at Blagoveschensk (Moiseenko et al., 1997). By 1990, a surface of about 200 square meters was excavated and several

hundreds bones were recovered from this locality. Most of them (more than 90%) belong to lambeosaurine dinosaurs. Bolotsky and Kurzanov (1991) briefly described a small part of the recovered lambeosaurine material under the name *Amurosaurus riabinini* and Godefroit et al. (2004) described this taxon in detail. Hadrosaurine hadrosaurids are also represented by cranial material, described as *Kerberosaurus manakini* Bolotsky and Godefroit, 2004. The Blagoveschensk locality has also yielded isolated teeth of the ropod dinosaurs (Alifanov and Bolotsky, 2002) and turtle fragments (Danilov et al., 2002).

Geological setting

The Blagoveschensk dinosaur locality is situated within the city limits of Blagoveschensk (Amur Region, Far Eastern Russia). The exposures of the dinosaur-bearing sediments of the Udurchukan Formation (lower Tsagayan Group) are limited to a hillside of a few metres high (Fig. 5). These are green-coloured claystones with a considerable amount of dispersed granules, so-called diamicts. A basal pebble lag with a maximum clast size of 20 cm occurs at the base of these sediments. The total thickness of the Cretaceous sediments in outcrop is estimated as 2–3 m. Indurated metamorphic rocks, which are weathered at the top, form the basal part of the outcrop. In outward appearance the weathered zone cannot be distinguished from the underlying rocks because the original texture of the metamorphic rocks is preserved. Only after a closer examination does it become evident that the top zone is friable and clay-rich in contrast to the indurated rocks below. These metamorphic rocks are part of the basement of the Zeya-Bureya Basin.

The dinosaur-bearing sediments are green-to-brown massive claystones with a considerable number of dispersed granules, so-called diamicts. These sediments can be divided into two units with a very similar appearance. Both consist dominantly of massive, clast-poor diamicts but have a coarser, clast-rich base. A basal pebble lag with a maximum clast size of 20 cm occurs locally at the base of unit 1, at the contact with the weathered metamorphic rocks. At the base of unit 2, a coarser-grained, clast-rich level occurs 0.4–0.75 m above the basement. Although dominantly matrix-supported, thin lenses (a few cm) of clast-supported conglomerates have been observed

within this unit. Although dinosaur elements have been found throughout the lower 75 cm of the Udurchukan Formation, they are particularly concentrated

at the base of the second unit. The recognition of these two units is the only indication of stratification within the Upper Cretaceous deposits at Blagoveschensk.

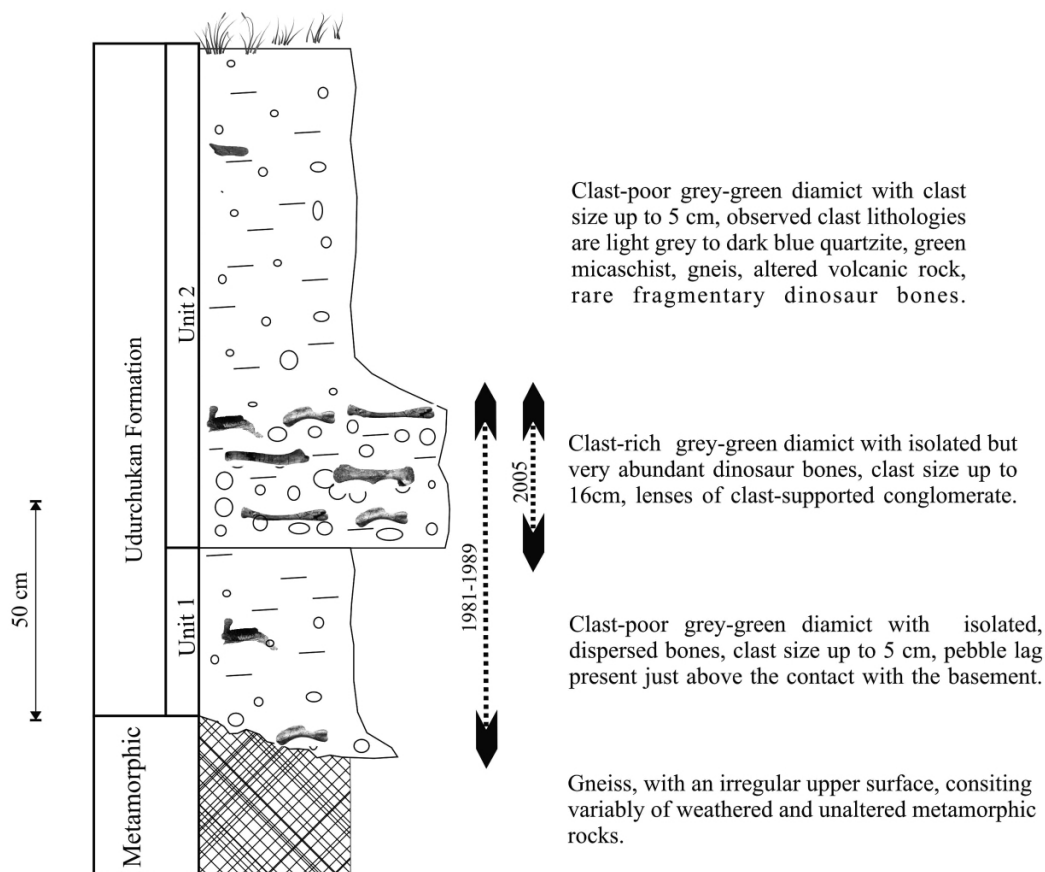

Fig. 5 Stratigraphic section of the dinosaur locality at Blagoveschensk (Russia) . Black arrows indicate the excavated layers

The clays are dominantly smectite with some illite and kaolinite. No bioturbation or paleosol development beyond inceptisols has been observed; the massive fabric with a mixture of unstratified fine and coarse material seems to be primary and not the result of post-depositional processes. Tabular beds of massive diamictites are typical for debris flow deposits and the presence of two units at the Blagoveschensk dinosaur locality indicates at least two flow events.

Taphonomy of the Blagoveschensk locality

Fig. 6A represents the distribution of the dinosaur bones collected during the 2005 field campaign. About 90% of the bones recovered at Blagoveschensk can be attributed to the lambeosaurine *Amurosaurus riabinini* (see below) . The few numbers of associated skeletal elements at Blagoveschensk indicates that the carcasses would have been disarticulated well before

the transportation of the bones. Although theropod shed teeth have been found in the bonebed, less than 2% of the bones exhibit potential tooth marks (Fig. 6B) : scavenging activity was therefore limited, or scavengers had at lot of preys at hand and had not to actively seek out the bones for nutrient intake. Perthotaxic features are very rare on the bones: they were not exposed subaerially for any significant length of time before transportation and burial. The under-representation of small and light skeletal elements, the dislocation of the dental batteries and the numerous fractured long bones suggests that most of the fossils were transported along a relatively important distance. The random orientation of the bones (Fig. 6C) might indicate a sudden end to transport before its stability can be reached (Lauters *et al.*, 2008) .

The size-frequency distributions of the femur,

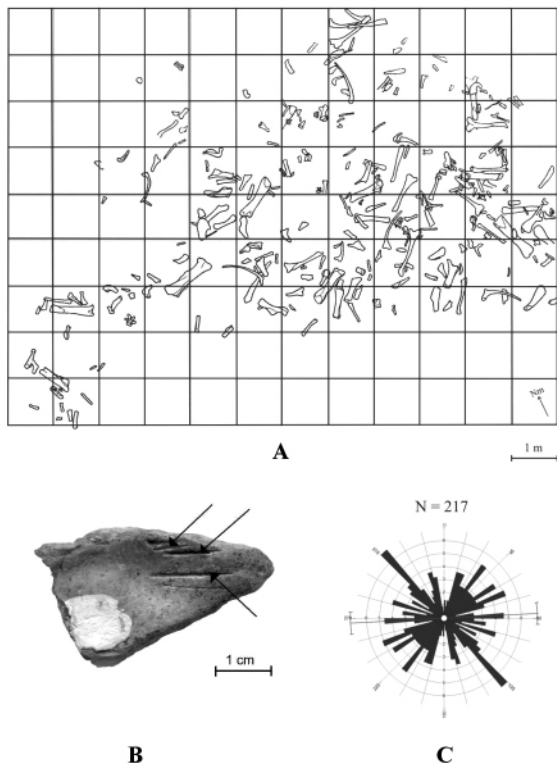

Fig. 6 A: map of the Blagoveschensk bonebed made during 2005 field campaign. B: dentary fragment displaying sub-parallel grooves, interpreted as predator or scavenger tooth marks. C: mirror rose diagrams with 5° petals for bones recovered at Blagoveschensk in 2005

tibia, humerus and dentary reveal an over-representation of late juveniles and small subadult specimens, indicative of an attritional mortality profile for the *Amurosaurus* population (Lauters et al., 2008). Predators preferentially killed younger, thus weaker specimens. However, the complete absence at Blagoveschensk of fossils that may be attributed to nestling to early juvenile individuals is surprising in an attritional model. Carpenter (1999) suggests that younger dinosaurs were usually segregated from the adults, and could join the herd only when they were half-grown. This hypothesis appears to fit the demographic data collected at Blagoveschensk, but also at Kundur and Wulaga.

The lambeosaurine *Amurosaurus riabinini* Bolotsky and Kurzanov, 1991

Holotype: AEHM 1/12, (Amur Natural History Museum, Blagoveschensk, Russia), associated left

maxilla and dentary.

Locality and horizon: Blagoveschensk, Amur Region, Far Eastern Russia. Udurchukan Formation, Maastrichtian, Upper Cretaceous.

Diagnosis: Prominent median process between basiptyergoid processes; sagittal crest particularly elevated on the caudal part of the parietal and forming a high, triangular and deeply excavated triangular process on the occipital aspect of the skull; squamosals separated from each other by this crest along their whole height; caudal process of postorbital particularly elongated, narrow, and regularly very convex dorsally; prefrontal forming a good half of the width of the floor for supracranial crest; ulna and radius sigmoidal both in lateral and in cranial views.

Abridged description (Fig. 7): Although most of the *Amurosaurus* specimens discovered to date belong to small to medium-sized individuals, some isolated bones suggest that this hadrosaurid could reach very large sizes, perhaps similar to or even larger than *Shantungosaurus giganteus*. The frontal remains relatively longer than wide, which is the primitive condition in ornithomorphs. Its rostral half is highly modified to form a strongly grooved platform that supported the base of the hollow crest. A median squamous doming can be observed in younger individuals. The dorsal aspect of the prefrontal is also modified to support the base of the hollow crest: it forms a long and very wide dorsal platform, in continuity with the frontal rostral platform. The postorbital is characterised by its elongated, narrow and dorsally convex caudal ramus. The parietal is proportionally short and wide, as usually observed in lambeosaurines. It bears a strong sagittal crest. In caudal view, the parietal forms a high and deeply excavated triangular process that overhangs the rostradorsal portion of the supraoccipital and completely separates the squamosals from each other. The median ramus and the lateral wall of the squamosal are particularly elevated. Two long and parallel ridges run along the lateral side of the squamosal, limiting the articular surface for the postorbital. The jugal of *Amurosaurus riabinini* is typically lambeosaurine in shape, with a rounded and symmetrically expanded rostral process. The jugal neck is particularly contracted. The maxillary facet of the jugal is wide and strongly striated for tight ligamentous attachment with

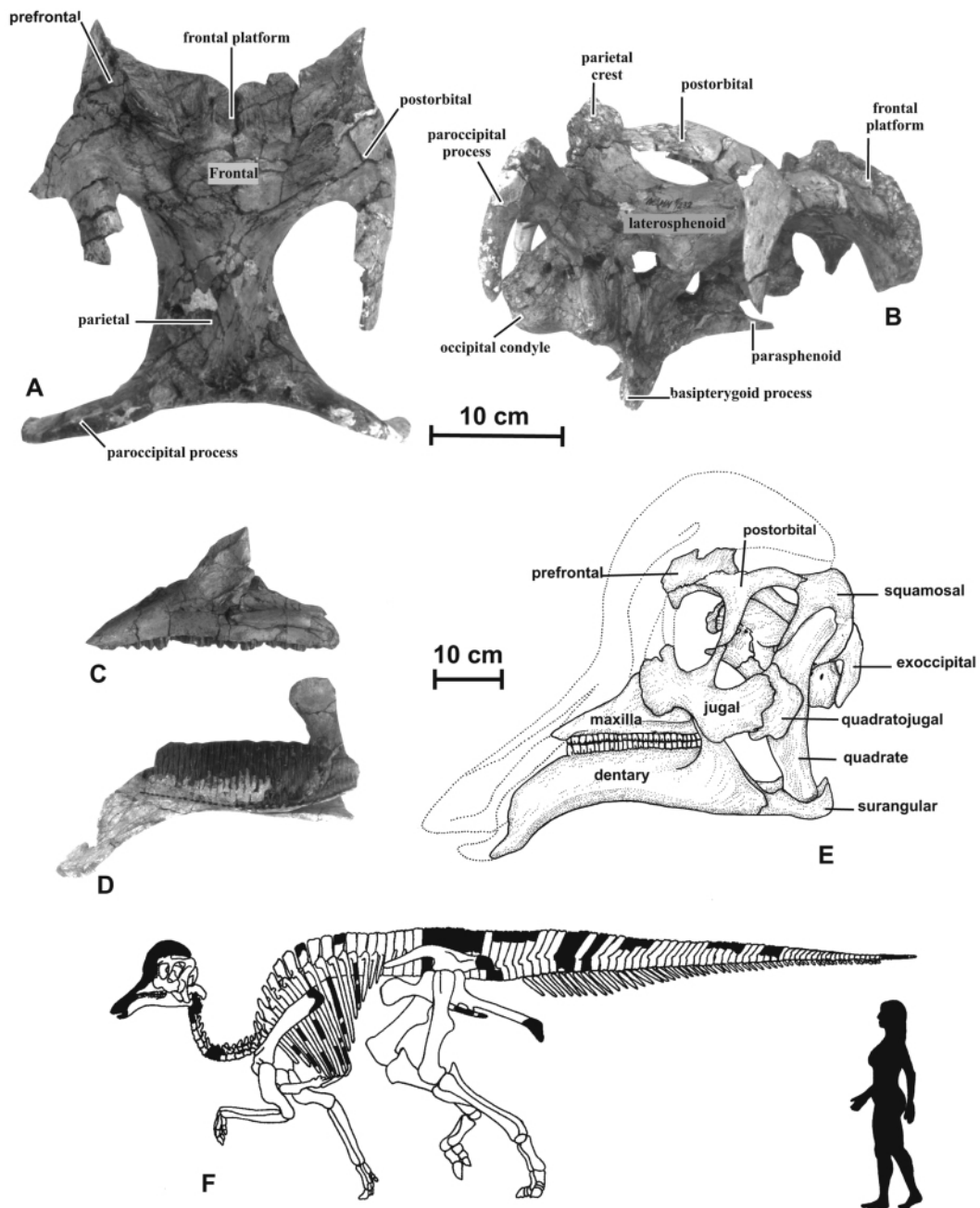

A-B: braincase (AEHM 1/232) in dorsal (A) and right lateral (B) views. C: left maxilla (AEHM 1/12) in lateral view. D: left dentary (AEHM 1/12) in medial view. E: reconstruction of the skull in left lateral view. F: reconstruction of the whole skeleton.

Fig. 7 *Amurosaurus riabinini* , from the Udurchukan Formation (Maastrichtian) of Blagoveschensk (Russia)

the maxilla. The maxilla is elevated , being about twice as long as high. The antorbital fenestra forms a very large ovoid canal that penetrates the dorsal process at the base of the lacrimal facet to communi-

cate with the excavated caudomedial surface of this process. The maxillary shelf is present , but is not prominent. The holotype maxilla bears about 39 teeth. The quadratojugal is thin and smoothly convex

both rostro-caudally and dorso-ventrally. Between the basiptyergoid processes, the basisphenoid bears a large but thin median process. The alar process is clearly separated from the basiptyergoid process and distinctly asymmetrical in lateral view. A well-developed horizontal groove runs along the rostral side of the pillar separating the auditory foramen from the postotic foramina; it is tentatively suggested that it would have transmitted the internal jugular vein. The paroccipital processes are long and wide, they descend ventro-laterally at their lateral tips, and their tips are approximately level with the ventral border of the occipital condyle. Both the prootic and the laterosphenoid are particularly robust. The dentary is strongly deflected ventrally, especially in larger specimens. In the holotype dentary, the diastema is about half the length of the dental battery. The coronoid process is high, robust, and inclined rostrally. The dentary teeth are diamond-shaped, with a height / width' ratio of about 3.5 for the teeth located in the middle of the dental battery. Incipient secondary ridges are sporadically developed on dentary teeth, both rostrally and caudally to the slightly sinuous median carina. The centra of most cranial cervical vertebrae are particularly wide and strongly opisthocoelous. The dorsal vertebrae are also unusually opisthocoelous and bear a strong ventral carina. A broad and shallow sulcus is developed along the ventral side of the sacrum. The scapular blade is long and dorso-ventrally narrow, with a length' / width' ratio >4.5. The most striking character of the coracoid of *Amurosaurus riabinini* is its massive size. Its lateral side bears an extremely prominent knob, which served as an attachment site for a well-developed *M. biceps*. The sternals are also massive, with an enlarged cranial plate and a shortened caudal handle. The humerus is typically lambeosaurine in shape, with a long and wide deltopectoral crest. The ulna is very robust, whereas the radius looks rather gracile. These two bones display a characteristic sigmoidal curvature, both in cranial and lateral views. The prepubis of *Amurosaurus riabinini* appears intermediate in shape between that of *Corytho-*

saurus casuarius (type 4' of Brett-Surman, 1989) and that of *Parasaurolophus cyrtocristatus* (type 5' of Brett-Surman, 1989). The ischial peduncle of the pubis is very prominent, whereas the pubic ramus of the ischium is very shortened. The obturator process of the ischium is small, as also observed in *Corythosaurus casuarius* (Brett-Surman, 1989). The ilium closely resembles that of lambeosaurines referred to as the *Corythosaurus* lineage by Brett-Surman (1989). The iliac blade is relatively high and bears a prominent antitrochanter. The femur is robust, with a well-developed globular femoral head. The cnemial crest of the tibia is particularly enlarged and strongly deflected laterally. The cranial ascending process of the astragalus is only slightly skewed laterally and strongly depressed in cranial view. The calcaneum is stout and sub-trapezoidal in outline.

The hadrosaurine *Kerberosaurus manakini* Bolotsky and Godefroit, 2004

Holotype: AEHM 1/319, (Amur Natural History Museum, Blagoveschensk, Russia), the caudal part of a cranium.

Locality and horizon: Blagoveschensk, Amur Region, Far Eastern Russia. Udurchukan Formation, Maastrichtian, Upper Cretaceous.

Diagnosis: Basiptyergoid process of prootic deeply excavated by a pocket-like depression; groove for *ramus ophthalmicus* (V_1) of trigeminal nerve particularly widened on lateral side of laterosphenoid; postotic foramina not limited rostrally by a prominent ridge; frontal particularly narrow medio-laterally; rostral margin of parietal depressed; circumnarial depression limited dorsocaudally by a strong, wide and flattened crest on the lateral side of the nasal around the external nares; very prominent hook-like palatine process on maxilla.

Abridged description (Fig. 8): *Kerberosaurus manakini* is based on disarticulated skull bones found within the Blagoveschensk dinosaur bonebed. Although the fossils described herein are particularly scarce and were not discovered in articulation, it is tentatively assumed that they all belong to a single

hadrosaurine species. In the current state of our knowledge , it is probably the most parsimonious solution , because of the osteological homogeneity of the available material. There is no data indicating that more than one hadrosaurine taxon coexisted at Blagoveschensk during Maastrichtian time. The prootic of *Kerberosaurus manakini* is devoid of a vertical groove running from the opening of the trigeminal nerve , as is usually observed in hadrosaurids. However , the ventral part of the prootic is strongly excavated ventral to this foramen , forming a pocket-like depression. Along the lateral side of the laterosphenoid , the horizontal groove for *ramus ophthalmicus* (V_1) of the trigeminal nerve is proportionally wider than in any other known hadrosaurid , but appears also rather short. The wide and deep carotid canal runs obliquely along the dorsal part of the basiptyergoid process , from the caudal surface of the basiptyergoid into the caudoventral wall of the hypophyseal cavity. The base of the paroccipital processes is widened , forming a greatly elongated shelf that extends caudodorsally dorsal to the foramen magnum. On the exoccipital condyloids , the foramen for the vagus (X) and glossopharyngeal (IX) nerves is not bordered rostrally by a strong carina extending towards the rostroventral border of the paroccipital process , as in other hadrosaurids. The frontal is proportionally elongated and very narrow medio-laterally. Its rostromedial corner is notched by the caudal margin of the fronto-nasal fontanella , well developed in juvenile hadrosaurines (Maryńska and Osmólska , 1979). The rostrolateral part of its dorsal surface forms an elongated rectangular groove , which was covered by the prefrontal. The frontal apparently did not participate in the orbital rim: the prefrontal and post-orbital facets are confluent on the lateral side of the bone. The prefrontal is a massive crescent-shaped element , with a long and flattened caudal ramus. Its caudal border is thickened and roughened for intimate contact with the postorbital. The nasal is formed by a caudal plate and a rostradorsal process. The caudal plate is flattened medio-laterally and relatively long. The tapering rostradorsal process is gently curved ven-

trally , but is not strongly arched as it is in *Gryposaurus*. Its lateral side bears a very prominent , flattened crest that closely follows the margin of the external naris to mark the dorsal and caudal limits of the circumnarial depression. The lateral wall of the squamosal is proportionally lower than that of typical lambeosaurines. An elongated and deep groove runs obliquely along the dorsal side of the rostral process to receive the caudal ramus of the postorbital. The jugal is lightly built and rostro-caudally elongated. Its rostral process is rounded , asymmetrical , and very strongly directed dorsally. The quadratojugal facet is extended and particularly deep. The maxilla is proportionally low , but robust. The jugal process is particularly prominent. In lateral view , it appears nearly symmetrical. Caudally to the dorsal process , the ectopterygoid shelf forms a particularly prominent hook-like palatine process that slopes medially and caudally. The maxillary dental battery of *Kerberosaurus manakini* is composed of about 50 tooth rows , each row being formed by five successive teeth , with two effective ones. Maxillary teeth are diamond-shaped , relatively elongated and perfectly symmetrical in lateral view. The quadrate is nearly perfectly straight and slender.

Kundur (N49°04'57. 5"/E130°51'34. 1")

History of the discoveries

In 1990 , V. A. Nagornii from the Far Eastern Institute of Mineral Resources found fossil bones in a road section along the Chita —Khabarovsk highway near the village of Kundur and sent them to Y. Bolotsky and his team. Large-scale excavations started at Kundur in 1999. This dinosaur locality , the third in the Amur Region , has yielded the nearly complete skeleton of a new lambeosaurine hadrosaurid , *Olorotitan arharensis* Godefroit , Bolotsky and Alifanov , 2003 , together with isolated bones and teeth belonging to theropods (Alifanov and Bolotsky , 2002) , nodosaurids (Tumanova *et al.* , 2004) and lindholme-mydid turtles (Danilov *et al.* , 2002) . The first multi-tuberculate mammal fossil ever discovered in Russia was also described from this locality (Averianov *et al.* , 2002) .

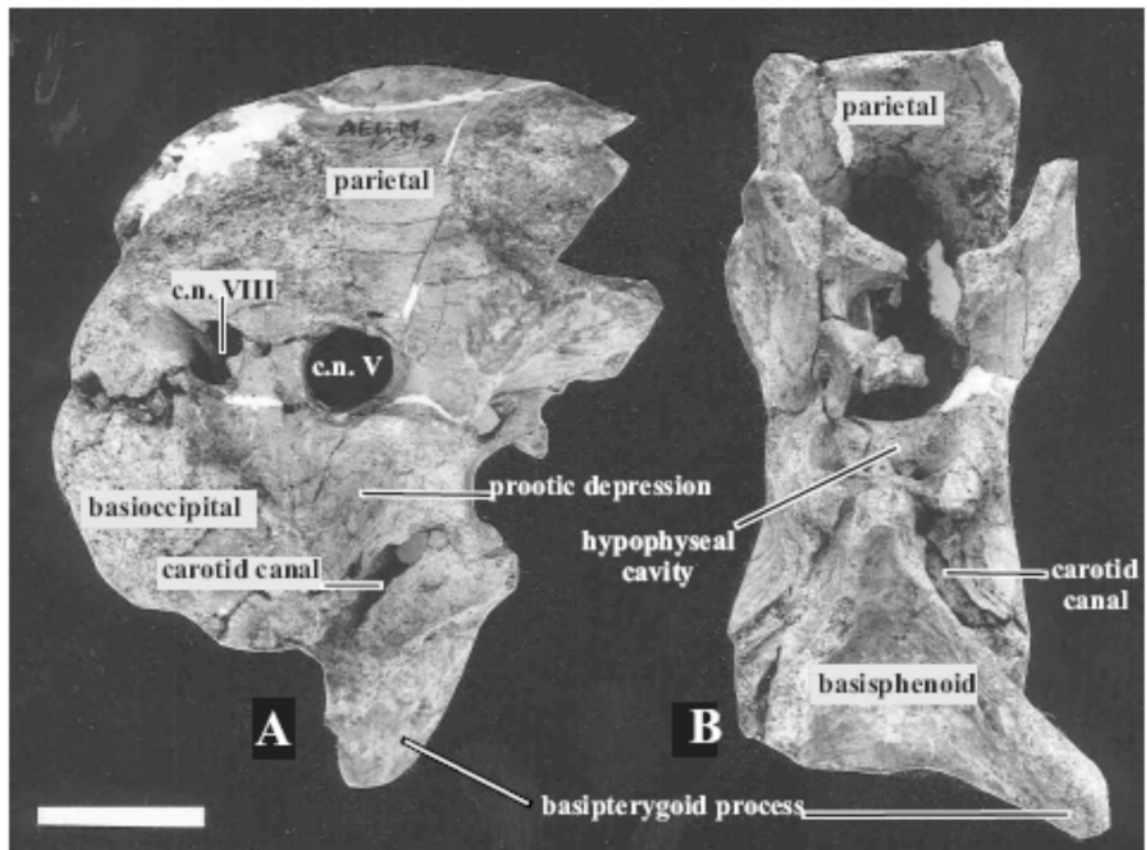

A-B: brainscase (AEHM 1/319) in right lateral (A) and ventral (B) views; scale bar = 5 cm. C: reconstruction of the whole skeleton.

Fig. 8 *Kerberosaurus manakini* , from the Udurchukan Formation (Maastrichtian) of Blagoveschensk (Russia)

Geological setting

The Kundur site , located 10 km southeast of the village Kundur , is situated in a continuous series of exposures of Campanian to Maastrichtian sediments along the Chita –Khabarovsk highway. These exposures allow the study of the contemporary environment of the dinosaurs. The Campanian sediments belong to the Kundur Formation , which is an equivalent of the upper part of the Zavitiiskaya Formation (Markevich and

Bugdaeva , 2001a , p. 80) . The Maastrichtian sediments are attributed to the Udurchukan and Bureya formations , respectively the lower and middle part of the Tsagayan Group. With the enlargement of the Chita –Khabarovsk highway during the summer of 2002 , several of the exposures were enlarged. The Kundur section was described in detail by Van Itterbeeck *et al.* (2005) .

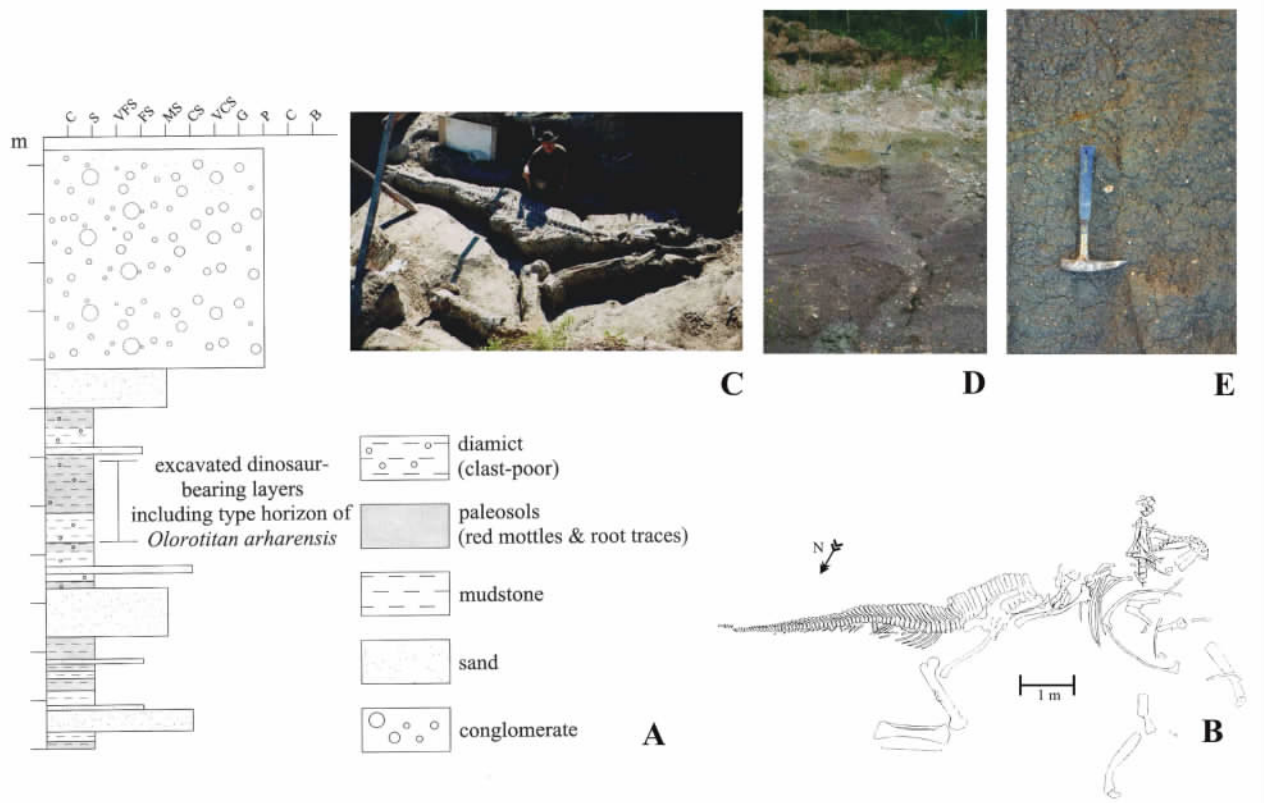

Fig. 9 A: lithostratigraphy of Exposure 18 at Kundur (Russia) on the opposite side of the road of the main dinosaur site. B: sketch of the *Olorotitan* skeleton excavated during summer of 2000 and 2001. C: picture of part of the *Olorotitan* skeleton excavated during summer of 2000. D: dystric argillisol at the top of the Udurchukan Formation (depth of the soil profile = 2m) . E: detail of dinosaur bearing clast-poor diamictite

The main fossil site occurs 3.25 m below the contact with the Bureya Formation (conglomerate at the top of the section , Fig. 9A) and has yielded near-complete dinosaur skeletons , together with a mixture of isolated bones. Most of the bones have an EW-orientation and lie in a horizontal position but a vertically oriented dentary and rib have been observed. As for the other sites , 90% of the bones belong to lambeo-

saurines. The fossil-bearing sediments consist of an olive-grey muddy matrix , with dispersed very coarse sand particles and pebbles < 2 cm , and can be described as a clast-poor diamictite (Fig. 9E) . The clays are dominantly smectite with some illite and kaolinite. These strata have a pattern of brown-coloured joints , some of which have evolved to minor faults.

The observed mixture of both fine and coarse ma-

terial is typical for sediment gravity flow deposits. The smectite-rich nature of the mud matrix is very favourable for mass flow deposits (Svendsen *et al.* , 2003) . The articulated nature of the unearthed *Olorotitan arharensis* skeleton (Fig. 9 B-C) indicates a rapid and *in situ* burial before decomposition of the soft parts , perhaps within a few days after death (Koster , 1987) . The horizontal orientation of the skeleton and its uniform preservation indicates that it was buried by one event. A sediment gravity flow can account for the rapid burial of such a large animal and even for its death (Loope *et al.* , 1998; 1999) . However , the near-complete nature of the skeleton (the left hind-limb , the right foot , the distal part of the forelimbs , and some dorsal vertebrae and ribs are missing) and the abundance of theropod shed teeth around the specimen suggest scavenging prior to burial , implying that the sediment gravity flow was not the cause of death.

The observed sediment gravity flow deposits have the characteristics of both debris flows and hyperconcentrated flows (Dasgupta , 2003) . Only areas with a distinct relief can generate debris flows. Recent debris flows show a correlation between the amplitude of the flow and the recurrence interval (Vallance *et al.* , 2003) : the largest debris flows have the largest recurrence interval (in the order of one or two centuries) . Their travel distance (5-25 km) is strongly controlled by local topography; debris flows of a given volume will have a larger travel distance in confined steep drainages than in broad drainages with gentle gradients. The height of the region of origin also determines the travel distance of the flow (Iverson , 1997) . Uplifted areas , located at a distance of a few tens of kilometers from the Kundur site , are known along the borders of the Lower Zeya Depression. Both the Turpan Uplift and the Lesser Khingang Mountains are possible source regions for such debris flows. Markevich and Bugdaeva (2001b) consider the palaeo-Khingang Mountains (*sensu* Turpan Uplift , Markevich and Bugdaeva , pers. com.) as the source region of these ancient flows and this hypothesis is confirmed by the flow data and the position of the

Kundur site within the basin. The large distance between the source region and the Kundur site make the recorded sediment gravity flow deposits exceptional phenomena , if they are indeed debris flows. However , the dominance of diamictites within the lower part of the Tsagayan Group indicates that these sediment gravity flows occurred frequently. One could argue that an event with a recurrence interval of a century or more could be classified as frequent on the scale of geological time. However , a more proximal source region for these debris flows cannot be excluded. More detailed palaeogeographical studies need to be conducted to determine the true source region of these sediment gravity flows. Such studies will be severely hampered by the lack of exposures in the present-day landscape.

The observed deposits could also be classified as hyperconcentrated flows. Such deposits have been observed in low-relief alluvial plain sedimentary environments at long distances from the mountain front , e. g. the dinosaur-bearing Cloverly Formation (Zaleha and Wiesemann , 2005) . With the current state of knowledge , the characterisation of the sediment gravity flow deposits as hyperconcentrated flows seems more likely considering their frequent occurrence and the distance to the mountain front.

At Kundur , the dinosaur bonebed is therefore found in a debris flow/hyperconcentrated flow i. e. an event bed , formed geographically very quickly. Besides this local event , the sedimentary environment reflected in the Udurchukan Formation is identical to that of the Yuliangze Formation , on the other side of the Amur River. The same type of reddish-purple palaeosol horizons have been recognised in the Kundur section. According to the classification of Mack *et al.* (1993) , this palaeosol can be attributed to the argillisol soil order , the equivalent of present-day ultil- and alfisols. These recent soil orders can only be distinguished on the basis of their base saturation. In fossil soils , this is impossible to measure and Mack *et al.* (1993) consequently regrouped these soil orders under the term argillisols. According to Retallack

(1988) , the absence or presence of chemically unstable minerals , such as feldspars , can be used as a proxy for base saturation. XRD-analysis of the soil horizons demonstrated the absence of feldspar in the clay fraction , indicative of a low base status , whereas feldspar and quartz form the principal non-clay minerals in the clay fraction in all the other samples from the Kundur section. So , these palaeosols can be classified as dystic argillisol (Mack *et al.* , 1993) , which is the fossil equivalent of the recent ultisols. Like these present-day soils , the studied palaeosol displays reddish colours resulting from the presence of iron oxides. Although ultisols can occur in any soil moisture and temperature regime except arid , they are best developed under warm and humid climates with a seasonal deficit of precipitation (Soil Survey Staff , 1999) . According to Mack and James (1994) , argillisol occur within the wet equatorial and the moist mid-latitude climatic belt.

The lambeosaurine *Olorotitan arharensis* Godefroit , Bolotsky and Alifanov , 2003

Holotype: AEHM 2/845 (Amur Natural History Museum , Blagoveschensk , Russia) , a nearly complete skeleton.

Locality and horizon: Kundur , Amur Region , Far Eastern Russia. Udurchukan Formation , Maastichtian , Upper Cretaceous.

Diagnosis: Lambeosaurine dinosaur characterized by the following autapomorphies: large helmet-like hollow crest higher than the rest of the skull and extending caudally well beyond the level of the occiput; very high postorbital process of jugal (ratio height of postorbital process / length of jugal = 1) ; rostral portion of the jugal shorter than in other lambeosaurines , with a perfectly straight rostral margin; very asymmetrical maxilla in lateral view , with ventral margin distinctly downturned; very elongated neck composed of 18 cervical vertebrae; tibia as high as the femur; shorter cnemial crest , about one fifth of tibia length.

Abridged description (Fig. 10) : *Olorotitan arharensis* was a rather large lambeosaurine , comparable

in size with *Parasaurolophus cyrtocristatus*: the holotype , a rather old adult specimen , is around 8 metres long. Its skull appears long and massive , mainly because of the important development of the hollow supracranial crest. This crest has an unusual shape , being markedly different from all North-American lambeosaurines: it extends caudally further than in helmet-crested forms. A bony plate found between the dorsocaudal part of the skull and the neck is identified as well-developed paired nasal bones. If this interpretation is correct , the nasals participated in more than half of the surface of the supracranial crest and this crest was distinctly more developed ventrally than in species of *Parasaurolophus*. The rostral part of the muzzle is rounded and very rugose , indicating that the ramphotheca was extensive in life. The large external naris is teardrop-shaped and , as usual in lambeosaurines , is completely surrounded by the premaxilla. The lateral premaxillary process is particularly large and extends caudally beyond the level of the occiput. The dorsal premaxillary process is responsible for the concave profile of the skull in lateral view. It extends far beyond the level of the occiput. The caudal part of the premaxilla progressively tapers dorsally; its dorsal surface is distinctly depressed along the midline , whereas its concave ventral surface was covered in life by the nasal. The nasal is poorly preserved , its largest part being crushed and displaced; it formed an important part of the hollow crest , being located ventrocaudally to the premaxilla. The quadrate is robust and curved , with a wide pterygoid wing. A very elongate postorbital process characterises the jugal of *Olorotitan arharensis*: the ratio height of postorbital process / length of jugal = 0.9; rostral to this process , the jugal is proportionally shorter than in other hadrosaurids. The rostral process of the jugal is also expanded dorso-ventrally , with a perfectly straight rostral border. The maxilla closely resembles that of *Tsintaosaurus spinorhinus* in being very markedly asymmetrical in lateral view and in having a very concave ventral alveolar border; the rostral maxillary shelf is very prominent. With its square outline , the prementary also re-

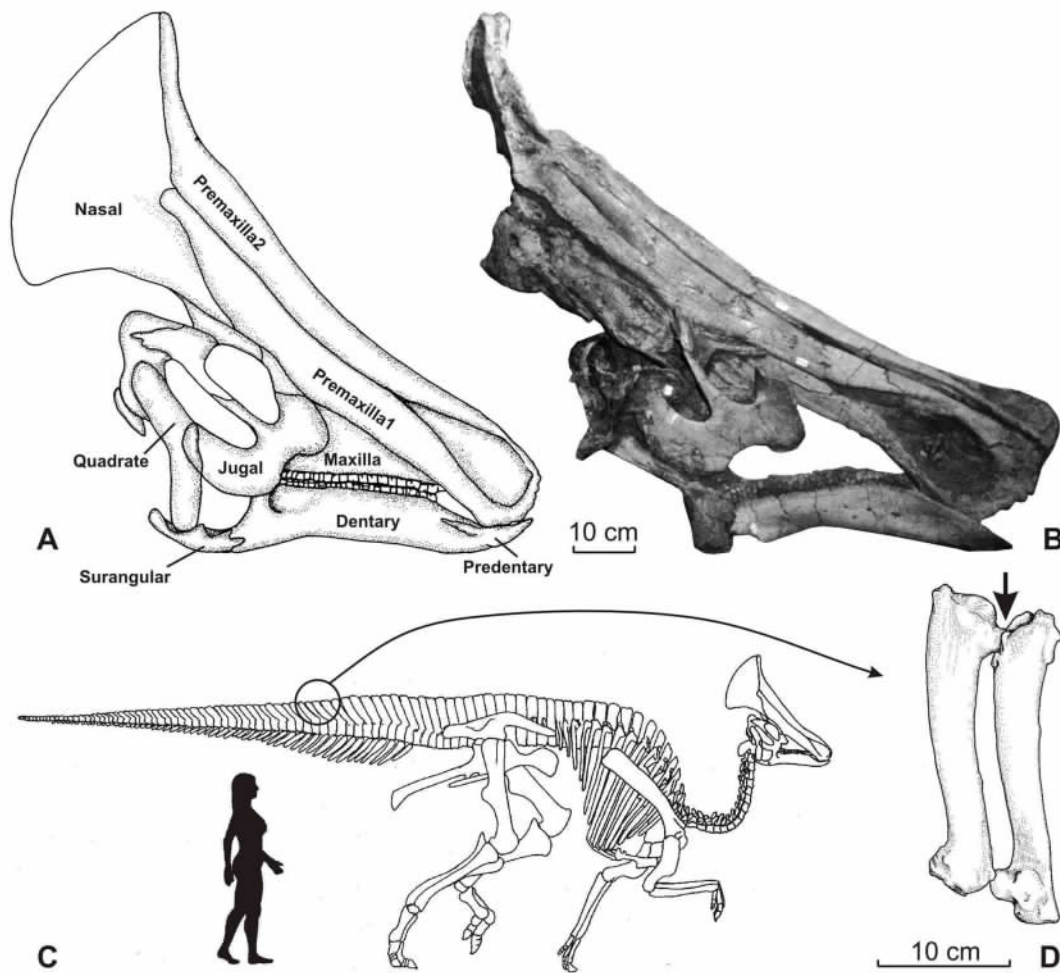

A: reconstruction of the skull in right lateral view (only bones that have been discovered are labelled) . B: main part of the skull of the holotype AEHM 2/845 in right lateral view (some deformation results from lateral compression of the skull) ; the largest part of the nasals , the maxillae , the surangulars , the left dentary and the predentary were found disconnected from this piece and are therefore not represented in this photograph. C: full skeletal reconstruction based on holotype AEHM 2/845. D: detail of the neural spines of the proximal caudal vertebrae , displaying the additional articulation.

Fig. 10 *Olorotitan arharensis* , from the Udurchukan Formation (Maastrichtian) of Kundur (Russia)

sembles that of *Tsintaosaurus spinorhinus*. The dentary is relatively low and not markedly deflected ventrally at its rostral end; the dental battery is composed of about 32 rows. The diastema is rather long , about two-thirds the length of the dental battery. Dentary teeth are proportionally less high than in *Charonosaurus jiyinensis*. The neck , including the proatlas , is completely preserved. It is remarkably elongated , formed by 18 cervical vertebrae , although a maximum of 15 cervical vertebrae was previously reported in hadro-

saurids (Lull and Wright , 1942; Horner *et al.* , 2004) . The neural spines of the dorsal vertebrae are not as elevated as those of *Hypacrosaurus altispinus* , but are similar in proportions with those of *Corythosaurus casuarius*. The neural spines of the sacrals are the tallest of the series , but are distinctly lower than in *Barsboldia sicinskii*. The tail is composed of more than 70 vertebrae in articulation. The neural spines and haemal arches on the caudal vertebrae are not as elongated as in *Hypacrosaurus altispinus*. On the prox-

imal third of the tail , the tips of adjacent neural spines form an additional articulation that made this part of the vertebral column particularly rigid: the proximal border of the distal spine forms a knob-like process that inserts into a cup-shaped depression on the distal border of the preceding spine. This feature , present on at last 6 vertebrae , seems too regular to be regarded as pathological; however , this latter hypothesis cannot be rejected pending the discovery of other *Olorotitan* specimens. The fused sternals are of lambeosaurine morphology , with a relatively long paddle. The scapula is more elongated than in other hadrosaurids: although the thin borders of this bone are slightly damaged , the L/W ratio may be confidently estimated at 6.2. The coracoid is stout , with a relatively small coracoid hook and a very prominent knob for insertion of a powerful *M. biceps*. The humerus is very robust , with a very prominent deltopectoral crest , as is usually observed in lambeosaurines. The ilium resembles that of *Corythosaurus casuarius* and *Lambeosaurus lambei* , with a ventrally deflected preacetabular process , a rather robust postacetabular process and a massive antitrochanter. The ischium is robust and its terminus is footed , as is usual in lambeosaurines; however , the general robustness of the bone and the development of the terminal foot are less than in *Hypacrosaurus altispinus* and *Parasaurolophus cyrtocristatus*. Both the femur and the tibia are equal in size. The lesser trochanter of the femur is particularly prominent , but the fourth trochanter of the femur and the cnemial crest of the tibia are moderately developed. The astragalus and calcaneum are fused to the tibia and fibula; such fusion can be observed in other adult lambeosaurines. The astragalus is laterally skewed , as observed in all hadrosaurids except *Parasaurolophus* and *Charonosaurus*.

A new hadrosaurine from Kundur

Hadrosaurine bones are also well represented in the Udurchukan Formation of Kundur and belong to a new taxon characterized by a shortened caudal plate on the nasal , a high coronoid process on the dentary , and a straight preacetabular process on the ilium. A

new phylogenetic analysis suggests that this still-unnamed new taxon is closely related to *Gryposaurus* , a genus represented in Campanian deposits from western North America (Godefroit *et al.* , 2009) .

Wulaga (N48°23'40.9"/E130°08'44.6")

History of the discoveries

In 2002 , the Geological Museum of Heilongjiang Province discovered a large bonebed in the Wulaga region (Jiayin County , Heilongjiang Province , China) . They excavated 315 m and unearthed more than 400 isolated bones (Hai , 2004) , together with numerous dinosaur skin impressions.

Geological context

Wulaga is situated in the farthest southeastern corner of the Zeya-Bureya Basin near the border with the Lesser Khingang Mountains. The sediments at Wulaga belong to the Yuliangze Formation (Sun *et al.* , 2002; Hai , 2004) . The exposure is limited to a short road section of a few metres high. As the layers are horizontal , the observed stratigraphic thickness is limited. The sediments are similar to those observed in the other dinosaur sites of this region. They represent a fluvial environment with yellow , coarse-grained channel deposits that have yielded eroded and fragmented bones; well-preserved bones are limited to the diamictite layers (Fig. 11) . These debris flow deposits have also yielded several skin imprints. The remarkable preservation of vertebrate bones and soft tissues in debris flow deposits has also been observed in Madagascar (Rogers , 2005) .

The lambeosaurine *Sahaliyania elunchunorum* Godefroit , Hai , Yu and Lauters , 2008

Holotype: GMH W453 (Geological Museum of Heilongjiang , Harbin , China) , a partial skull.

Locality and horizon: Wulaga , Heilongjiang Province , China. Yuliangze Formation , Maastrichtian , Upper Cretaceous.

Diagnosis: Lambeosaurine dinosaur characterised by the following autapomorphies: paroccipital processes long , very slender , with a slightly convex dorsal border and a slightly concave ventral border; lateral depressions on the dorsal surface of the frontal

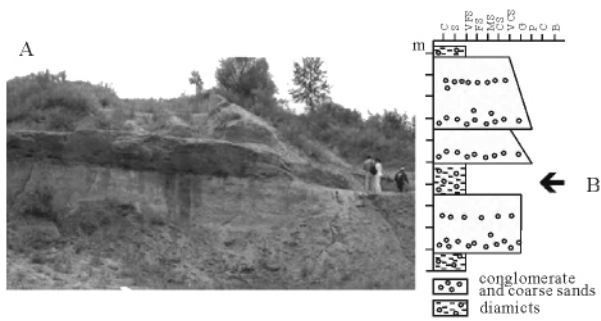
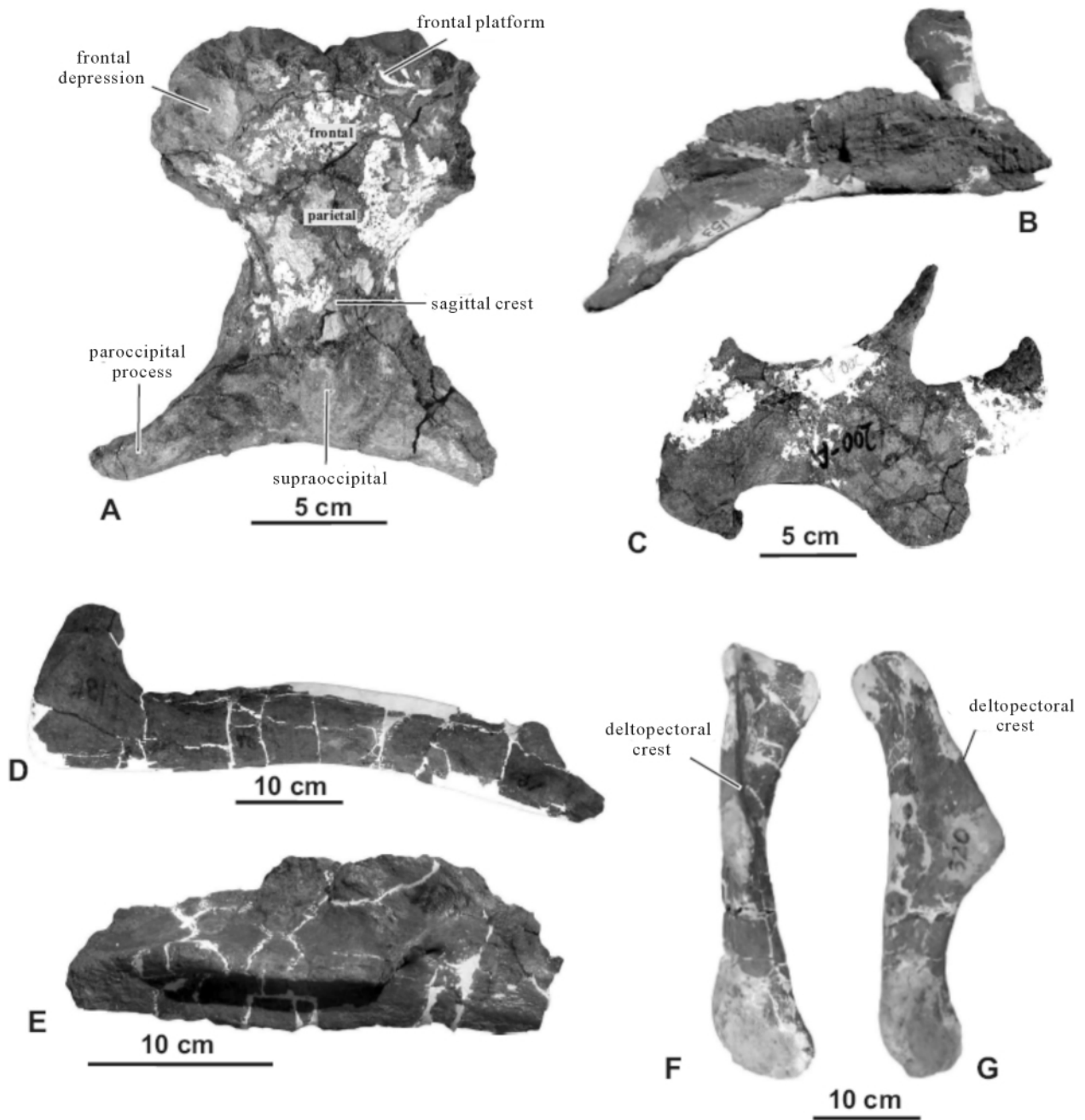

Fig. 11 A: Wulaga dinosaur site (China) , peoples on the right hand side of the picture are standing on the excavated surface. B: Lithostratigraphic column of the Wulaga dinosaur site , black arrow indicates dinosaur-bearing horizon

better developed than in other lambeosaurines , and not associated with a median doming of the bone; quadratojugal notch displaced ventrally; middle of the notch located well below the middle of the height of the quadrate; prepubic blade always more expanded dorsally than ventrally. Also differs from *Charonosaurus* , *Olorotitan* , *Corythosaurus* , and *Parasaurolophus* by the important ventral deflection of the rostral part of its dentary , which forms an angle of about 30° with the long axis of caudal part of the bone; differs from *Amurosaurus* by the symmetrical alar process on its basisphenoid , its frontals wider than long and by its well-developed maxillary shelf; differs from *Charonosaurus* and *Parasaurolophus* by the short rostral platform of its frontal; differs from *Olorotitan* by the rounded rostral process of its jugal , by the straight ventral margin of its maxilla , and by the longer preacetabular process of its ilium (ratio ilium length / preacetabular length = 2.1) ; differs from *Tsintaosaurus* by the presence of a rostral platform on its frontal and by the median ramus of its squamosal lower than its paroccipital process.

Abridged description (Fig. 12A-C) : As it is usual in dinosaur localities from the Amur/Heilongjiang region , most of the bones belong to lambeosaurine hadrosaurids. Differences with *Charonosaurus* , *Amurosaurus* and *Olorotitan* are important enough to justify the erection of a new genus. The paroccipital processes of *Sahaliyana* are longer than in *Charonosaurus* ,

they are pendant , descending ventrolaterally at their lateral tips , but much more slender than in *Amurosaurus*. On the lateral wall of the braincase , the rostrally-directed horizontal sulcus for *ramus ophthalmicus* (V_1) and the ventrally-directed vertical sulcus for *ramus mandibularis* (V_3) of the trigeminal nerve are less clearly marked than in *Amurosaurus* and *Olorotitan*. The alar process of the basisphenoid is prominent and nearly symmetrical in lateral view , closely resembling the condition observed in *Charonosaurus*. Between the basiptyergoid processes , a large median process is developed , as in *Amurosaurus*. With a length / minimal width' ratio = 1.5 , the parietal is proportionally much wider than in *Amurosaurus*. The rostral portion of its dorsal surface is very slightly convex. Caudally , it forms a low sagittal crest. Although it is eroded , this crest is much less developed than in *Amurosaurus* and *Olorotitan*. The frontal is distinctly wider than it is in *Amurosaurus*. The frontal platform is short , contrasting with the condition observed in *Charonosaurus* , but wider than in *Amurosaurus*. Between the rostral platform and the lateral contact area for the prefrontal , the dorsal surface of the frontal forms a pair of lateral cup-shaped depressions. The jugal is proportionally short , but very robust , contrasting with the more slender jugals of *Amurosaurus* and *Charonosaurus*. The jugal neck appears more robust than in other hadrosaurids described to date. The rostral shelf of the maxilla is better developed than in *Amurosaurus*. The quadrate is proportionally low and robust. In lateral view , the most striking character that can be observed in the lambeosaurine dentaries discovered at Wulaga is the important ventral deflection of their rostral part , forming an angle of about 30° with the long axis of the caudal part of the bone. In large adult specimens , the deflection of the ventral margin of the dentary usually begins somewhat caudally to the middle of the bone. The distance between the ventral margin of the dental ramus and the line tangent to the most ventral point of the mandibular symphysis is always more important than the height of the dental ramus , taken in the middle of the dental battery. This



A: Braincase of *Sahaliyania elunchunorum* (GMH W453) in dorsal view. B: right dentary of *Sahaliyania elunchunorum* (GMH W153) in medial view. C: left jugal of *Sahaliyania elunchunorum* (GMH W200-A) in lateral view. D: right dentary of *Wulagasaurus dongi* (GMH W184) in lateral view. E: right maxilla of *Wulagasaurus dongi* (GMH W400-10) in lateral view. F-G: right humerus of *Wulagasaurus dongi* (GMH W320) in cranial (F) and medial (G) views

Fig. 12 Hadrosaurid material from the Yuliangze Formation (Maastrichtian) at Wulaga (China)

character can be observed in *Tsintaosaurus spinorhinus*, from the Wangshi Series of Shandong Province, and also in the holotype of *Amurosaurus riabinini*. In

North American lambeosaurines, and in *Charonosaurus* and *Olorotitan*, on the other hand, the height of the dental ramus is always more important than the

ventral deflection of the rostral part , even in large adult specimens. The postcranial skeleton of *Sahaliyania* displays a typical lambeosaurine morphology , without diagnostic characters.

The hadrosaurine *Wulagasaurus dongi* Godefroit , Hai , Yu and Lauters , 2008

Holotype: GMH W184 (Geological Museum of Heilongjiang , Harbin , China) , a right dentary.

Locality and horizon: Wulaga , Heilongjiang Province , China. Yuliangze Formation , Maastrichtian , Upper Cretaceous.

Diagnosis: Hadrosaurine dinosaur characterised by the following autapomorphies: very slender dentary , with a ratio length of the dentary battery / maximum height of the dental ramus taken around the middle of the dental battery > 4.5 ; lateral side of dentary not pierced by foramina; edge of the deltopectoral crest oriented quite cranially; humeral articular head extends distally as a very long and prominent vertical ridge; inner tuberosity much better developed than outer tuberosity on the proximal end of the humerus.

Also differs from all other known hadrosaurines by its short sagittal , less than 2/3 the length of the parietal; differs from *Gryposaurus* , *Kerberosaurus* , *Prosaurolophus* , *Saurolophus* , *Edmontosaurus* and *Anatotitan* by its short supraoccipital-exoccipital shelf.

Abridged description (Fig. 12 , D-G) : On the lateral wall of the braincase , the foramen for c. n. IX and X is bordered rostrally by a prominent ridge extending from the ventral border of the paroccipital process to the rostroventral corner of the exoccipital condyloid. This pillar is not developed in *Kerberosaurus*. A ventrally-directed sulcus for transmission of *ramus mandibularis* (V_3) of the trigeminal nerve , not developed in *Kerberosaurus* , runs vertically from the opening for c. n. V. Dorsal to the foramen magnum , the median surface of the exoccipital-opisthotic does not really form an elongated shelf , as is observed in *Kerberosaurus* and derived North American hadrosaurines. It more closely resembles the condition observed in , for example , *Maiasaura* and *Brachylophosaurus*. Between the basiptyergoid processes , there is

also a well-developed median process , not developed in *Kerberosaurus*. The alar process of the basisphenoid , which conceals the Vidian Canal , is well-developed and bilobate. The sagittal crest is strongly developed on the caudal part of the parietal , but is distinctly shorter than in *Kerberosaurus*. The rostral portion of the parietal is apparently not depressed around the contact area with the frontals , as in *Kerberosaurus*. The jugal is incompletely preserved , but closely resembles the condition observed in non-edmontosaur hadrosaurines. The lateral side of the maxilla forms a very short and low jugal process , which is very concave and slightly faces dorsally. This condition contrasts with the wide and prominent jugal process observed in *Kerberosaurus* and in the new hadrosaurine from Kundur. Ventral to the jugal process , the lateral side of the maxilla is pierced by a single foramen. More than three foramina are usually observed in other hadrosaurines. With a ratio length of the dentary / maximum height of the dental ramus > 7 , the dentary of *Wulagasaurus* is proportionally much more elongated and slender than those of any other hadrosaurid described to date. The diastema , about 4 times shorter than the dental magazine , is relatively shorter than in other hadrosaurines. There is no trace of foramina on the lateral side of the dentary , as usually observed in hadrosaurids. The most striking character of the humerus of *Wulagasaurus* is its deltopectoral crest , oriented quite cranially , at an angle of 90 with its usual orientation. Of course , this configuration of the deltopectoral crest influences the whole morphology of the bone. The bicipital gutter is much deeper and , on the caudal side of the bone , the humeral head looks more prominent than in other hadrosaurids. The humeral head extends distally as a very long and prominent vertical ridge , and is much more prominent than in other hadrosaurids. Because of the concomitant cranial orientation of the deltopectoral crest and the important development of the caudal crest , the craniocaudal maximum diameter of the humerus is much more important than the mediolateral diameter , which is also an uncommon character among hadrosaurids. Also

contrasting to the normal hadrosaurid condition , the inner tuberosity is much better developed than the outer tuberosity on the proximal end of the humerus.

Phylogenetic relationships of hadrosaurid dinosaurs

A cladistic analysis of hadrosaurid dinosaurs was performed , using the PAUP* 4.0b10 program (Swoford , 2000) , in order to determine the phylogenetic position of the taxa discovered in the Amur Region and Heilongjiang Province within this clade. The resulting cladogram is based on 56 cranial , dental and postcranial characters. The non-hadrosaurid Hadrosauroidae *Bactrosaurus johnsoni* , recently revised by Godefroit *et al.* (1998) , has been chosen as outgroup , because its anatomy is now particularly well documented and familiar to the authors of the present paper. The characters used in the present analysis are described and discussed in Appendix 1 , the data matrix is presented in Appendix 2 , and a complete list of apomorphies is found in Appendix 3. The heuristic search option found one single most parsimonious tree , with a length of 80 steps , a consistency index (CI) of 0.92 and a retention index (RI) of 0.97 (Fig. 13) . This cladogram confirms the division of Hadrosauridae into Hadrosaurinae and Lambeosaurinae , as presented now by most authors. The four lambeosaurine taxa currently studied in the Maastrichtian of Amur Region and Heilongjiang Province do not form a monophyletic group , but occupy well-separated places within the cladogram. Therefore , the differences observed between them cannot be explained by intra-specific (sexual dimorphism , ontogeny) or intra-generic variations. Despite its Maastrichtian age , *Amurosaurus* occupies a relatively basal position within the lambeosaurine clade: its frontal is not as shortened as for example in *Charonosaurus* and in typical lambeosaurines from North America (character 7) . *Charonosaurus* forms the sister-taxon of the late Campanian lambeosaurine *Parasaurolophus*. Both share the following cranial and postcranial synapomorphies: parietal completely excluded from the occiput (character

1) , rostral platform of frontal extending above the rostral portion of the supratemporal fenestra (character 8 (2)) , dorsal surface of postorbital thickened to form a dorsal promontorium (character 28) , distal head of fibula greatly expanded and club-shaped (character 54) , and cranial ascending process of astragalus equilateral in shape (character 55) . *Olorotitan* belongs to the corythosaur clade , characterised by the caudal extension of the lateral premaxillary process (character 13) and the enlargement of the *Cavum nasi proprium* (character 18) . It forms an unresolved trichotomy with the North American genera *Corythosaurus* and *Hypacrosaurus* , with which it shares the enlargement of the nasal that forms around half of the hollow crest (character 19 (2)) . *Sahaliyana* may be regarded as a derived lambeosaurine , because it is characterised by the following unambiguous characters: a shortened frontal , with a posterior length / maximal width < 0.6 (character 7 (1)) , and 42-45 tooth positions in dentary tooth row [character 41 (2)] . However , the position of *Sahaliyana* within this group cannot be resolved. A more precise evaluation of the phylogenetic position of *Sahaliyana* will require the discovery of more complete specimens , with preserved supracranial crest structures.

Hadrosaurines are characterised by the following unambiguous synapomorphies: maxilla with a long and robust caudal portion (character 32) and tapering distal end of the ischium [character 53 (2)] . *Wulagasaurus* appears to be the most basal hadrosaurine known so far. Its sagittal crest is relatively short as in *Bactrosaurus johnsoni* , other basal hadrosauroids , and lambeosaurines. In all other considered hadrosaurines , on the other hand , the parietal crest is much longer , more than two-thirds the length of the parietal (character 3) .

The sauroloph clade (*Prosaurolophus* and *Saurolophus*) is characterised by the development of a supracranial crest , excavated laterally by the circumnarial fossa [character 20 (2)] . The present analysis places *Kerberosaurus* as the sister-taxon of the sauroloph clade , on the basis of the exclusion of the frontal

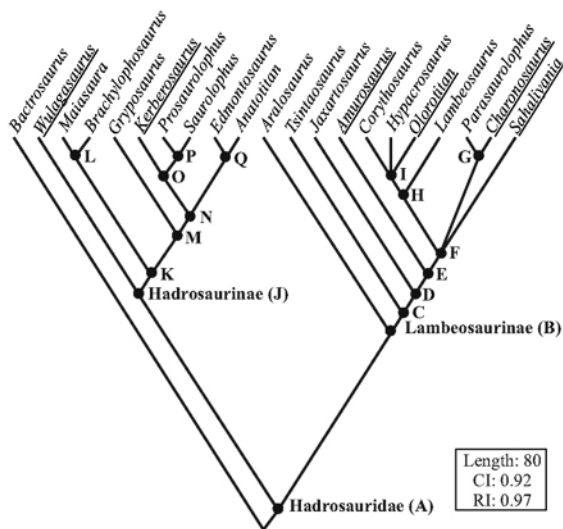

Fig. 13 Phylogenetic relationships of Hadrosauridae (Taxa found in the Amur/Heilongjiang region are underlined. Letters correspond to nodes defined in Appendix 3)

from the orbital rim (character 5, convergently evolved in Lambeosaurinae).

Palaeobiogeography of hadrosaurid dinosaurs

The results of cladistic analyses are interesting from a palaeobiogeographical point of view. Norell (1992) defined ghost lineages as missing sections of a clade implied by phylogeny. As sister taxa have the same time of origin, it is therefore possible to establish the minimal age for the origin of clades: the origin of a clade cannot occur later than the first occurrence of its sister taxon. Ghost lineage duration can be calibrated using a geochronological scale: for sister taxa, it is the difference between the first occurrence of the younger taxon and the first occurrence of the older one.

Fig. 14 represents the ghost lineages identified for lambeosaurine phylogeny. *Sahaliyania* has not been taken into consideration because of the uncertainties concerning its phylogenetic position. It suggests that lambeosaurines have an Asian origin. Indeed, the most basal lambeosaurines are successively *Tsiniaosaurus spinorhinus*, from the Wangshi Formation

(Campanian, according to Buffetaut, 1995), *Jaxartosaurus aralensis*, from the Syuksyuk Formation of Kazakhstan (Santonian, according to Averianov and Nessov, 1995), and *Amurosaurus riabinini*, from the Maastrichtian Udurchukan Formation of Amur Region in Russia. In western North America, the oldest well-dated lambeosaurines have been discovered in upper Campanian formations (Horner et al., 2004); all belong to the advanced parasauroloph or corythosaur clades. The most parsimonious hypothesis is therefore that ancestors of the parasauroloph and corythosaur clades migrated from eastern Asia towards western North America before or at the beginning of the late Campanian. Many other dinosaur taxa followed this migratory route during the Cretaceous: basal Neoceratopsia (Chinnery and Weishampel, 1998), Ankylosauridae (Maryńska, 1977), Tyrannosauroidae (Xu et al., 2004), and Troodontidae (Russell and Dong, 1993). A land route between Asian and Cordilleran America across the Beringian isthmus probably opened during the Aptian–Albian and persisted during the Late Cretaceous (Jerzykiewicz and Russell, 1991; Russell, 1993). *Charonosaurus*, from the Maastrichtian of Heilongjiang Province, is the sister-taxon of *Parasaurolophus* from the late Campanian of western North America (Sullivan and Williamson, 1999). *Olorotitan*, from the late Maastrichtian of Amur Region, is the sister-taxon of *Corythosaurus* and *Hypacrosaurus* from the late Campanian–early Maastrichtian of western North America. Both situations suggest independent migration from western North America to Asia before the late Maastrichtian.

Fig. 15 represents the ghost lineages identified for hadrosaurine phylogeny. As discussed above, *Wulagasaurus* is probably late Maastrichtian in age. The oldest relatively well-dated representative for the sister-group of *Wulagasaurus* is probably *Gryposaurus latidens*, from Lithofacies 3 of the Two Medicine Formation in Montana (oldest occurrence around 80 million years; Horner et al. 2001). This means that the *Wulagasaurus* lineage must have diverged from the lineage leading to more advanced hadrosaurines at

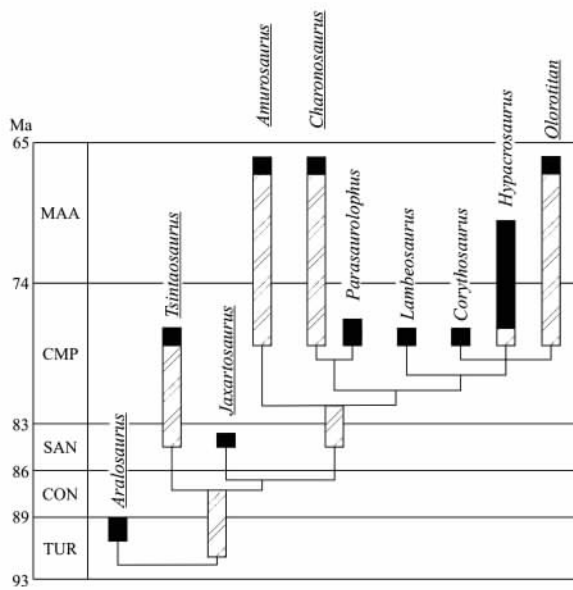

Solid symbols indicate stratigraphical occurrence of a taxon , whereas hatched symbols indicate ghost lineages. Asian taxa are underlined. *Abbreviations:* CMP , Campanian; MAA , Maastrichtian; SAN , Santonian. Dates are millions of years before present.

Fig. 14 Stratigraphically-calibrated cladogram of phylogenetic relationships of Lambeosaurinae

least by the early Campanian , yielding a GLD of approximately 13 million years for the *Wulgasaurus* lineage. Such a high GLD value means that a number of taxa have yet to be discovered if the phylogenetic continuity , as implied by the obtained topologies , is to be maintained. Within the sauroloph clade , the genus *Sauroplophus* is known both in western Canada (Horse-shoe Canyon Formation , lower Maastrichtian) and in Mongolia (Nemegt Formation , ? lower Maastrichtian) . Its sister taxon , *Prosauroplophus* , is only known in western North America and is older (Dinosaur Park Formation and Two Medicine Formation , late Campanian) ; thus , *Sauroplophus* probably migrated from North America to Asia at the end of the Campanian , or at the beginning of the Maastrichtian. The common ancestor for *Kerberosaurus* and for the sauroloph clade also most likely lived in western North America before or at the beginning of the late Campanian.

It may therefore be concluded that , despite the

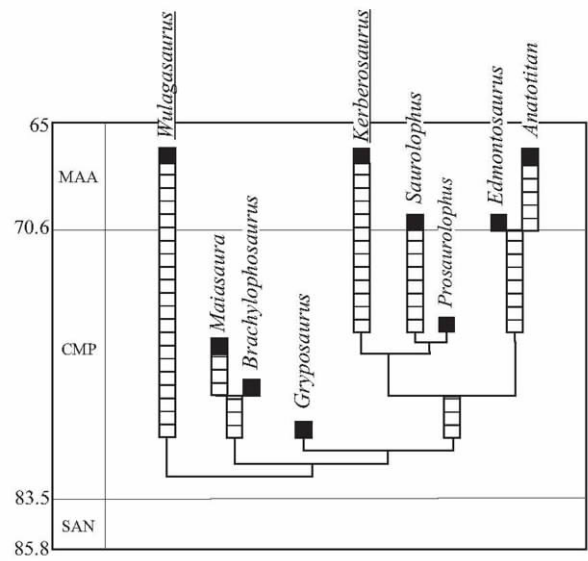

Solid symbols indicate stratigraphical occurrence of a taxon , whereas hatched symbols indicate ghost lineages. Asian taxa are underlined. *Abbreviations:* CMP , Campanian; MAA , Maastrichtian; SAN , Santonian. Dates are millions of years before present. v

Fig. 15 Stratigraphically-calibrated cladogram of phylogenetic relationships of Hadrosaurinae

fact that the Beringian isthmus was situated in the polar region , many faunal exchanges occurred between Asia and western North America , so both regions seem effectively merged from a biogeographical point of view by Campanian-Maastrichtian time. Although the major direction of emigration for dinosaurs seems to have been from Asia to western North America , several independent hadrosaurid lineages also appear to have crossed the Beringian isthmus from east to west.

Because the most primitive lambeosaurines and hadrosaurines were discovered in Asia , it may therefore be concluded that this continent constitutes the birthplace for the monophyletic clade Hadrosauridae.

As previously noted by Godefroit *et al.* (2000 , 2001) , Maastrichtian dinosaur faunas from the Amur Region are completely different from potentially synchronous Lancian faunas from western North America. Ceratopsian herbivorous dinosaurs , including *Triceratops* , *Torosaurus* and *Leptoceratops* (Lehman , 1987 ;

Russell and Manabe ,2002) usually dominate the latter. Hadrosauridae are also usually well represented by members of the edmontosaur clade (*Edmontosaurus* and *Anatotitan*). The titanosaur *Alamosaurus* also characterises Lancian dinosaur assemblages in Utah , New Mexico , Colorado and Texas. Lambeosaurinae apparently disappeared from western North America by late Maastrichtian time , or are represented only by very scarce and doubtful material (Boyd and Ott , 2002) . On the other hand ,Lambeosaurinae dominate Maastrichtian dinosaur localities from the Amur Region , where ceratopsians and titanosaurs are not represented.

The development of very different kinds of dinosaur communities during the Maastrichtian may reflect some kind of geographical isolation between eastern Asia and western North America during this time , or important differences in climatic or palaeoecological conditions. According to Markevich and Bugdaeva (2001a) , the Maastrichtian dinosaurs from the Amur Region lived along the banks of lakes and river , under a warm-temperate and relatively arid climate. Johnson (2002) showed that the Hell Creek Formation of the Dakotas was a forested environment , similar in appearance to a living mixed deciduous and evergreen broad-leaved forest. According to Russell and Manabe (2002) , the near absence of lambeosaurines in the Hell Creek Formation could be taken as evidence of a uniform coastal wetland environment , usually avoided by these animals. However , the Lancian localities from western North America represent a relatively wide geographic-environmental range , including coastal lowlands , alluvial plains and piedmont lithosomes. Lambeosaurines are apparently absent from all of these different palaeoenvironments in western North America.

The present analysis is based on the assumption that the dinosaur localities in the Amur Region and Heilongjiang Province are late Maastrichtian in age , a hypothesis that still needs to be corroborated by further palynological analyses and independent calibrations , as previously explained. Therefore , the possi-

bility cannot be excluded that the observed differences between the Maastrichtian dinosaur faunas from Amur Region and the Lancian' faunas from western North America may reflect temporal ambiguity rather than spatial differentiation.

Conclusions

The Maastrichtian dinosaur fauna discovered in the Amur Region is unique in the abundance , diversity and excellent state of preservation of hadrosaurid dinosaurs. Hollow-crested lambeosaurine hadrosaurids are particularly well represented. It brings to palaeontologists new insights on dinosaur biodiversity at the end of the Cretaceous , before the complete extinction of non-avian dinosaurs , 65 million years ago. In any case , it demonstrates that different kinds of dinosaur communities lived around the world by latest Cretaceous times , helping to refute previous assumptions of a gradual and diachronous extinction of the dinosaurs , suggesting instead a sudden demise close to the end of the Cretaceous. Speculations and scenarios about dinosaur extinction pattern must take the discoveries outside North America into consideration.

Acknowledgements

Darren Naish , Ian Harding , David Norman and Xabier Pereda-Suberbiola have carefully read a first version of this paper and made useful comments. The following institutions supported our researches: the Belgian State , Federal Scientific Policy , S&T bilateral co-operation project BL/36/C22-R12; National Geographic Society project 6970-01; Jurassic Foundation; FWO; FNRS; NSFC Project 30220130698. P. L. is a PhD student at the Free University of Brussels and her researches are supported by the Fonds pour la Formation à la Recherche dans l'Industrie et dans l'Agriculture.

References

- Alifanov V R , Bolotsky Y L. 2002. New data about the assemblages of the Upper Cretaceous carnivorous dinosaurs (Theropoda) from the Amur Region// Kirillova G L. (ed.) . Cretaceous continental margin of East Asia: stra-

- tigraphy , sedimentation , and tectonics. Khabarovsk: Unesco-IUGS-IGCP , 25-26.
- Averianov A O , Bolotsky Y L , Godefroit P. 2002. First multituberculate mammal from Russia// Kirillova G L (ed.) . Cretaceous continental margin of East Asia: stratigraphy , sedimentation , and tectonics. Khabarovsk: Unesco-IUGS-IGCP , 27-28.
- Averianov A O , Nessov L. 1995. A new Cretaceous mammal from the Campanian of Kazakhstan. *Neues Jahrbuch für Geologie und Paläontologie , Monatshefte* , 65-74.
- Bolotsky Y L , Kurzanov S K. 1991. The hadrosaurs of the Amur Region // *Geology of the Pacific Ocean Border*. Blagoveschensk: Amur KNII , 94-103. (in Russian)
- Bolotsky Y L , Godefroit P. 2004. A new hadrosaurine dinosaur from the Late Cretaceous of Far Eastern Russia. *Journal of Vertebrate Palaeontology* , 24: 354-368.
- Boyd C , Ott C J. 2002. Probable lambeosaurine (Ornithischia , Hadrosauridae) specimen from the Late Cretaceous Hell Creek Formation of Montana. *Journal of Vertebrate Paleontology* , 22 (Suppl. to 3) : 38A.
- Brett-Surman M K. 1979. Phylogeny and palaeoecology of hadrosaurian dinosaurs. *Nature* , 277: 560-562.
- Brett-Surman M K. 1989. A revision of the Hadrosauridae (Reptilia: Ornithischia) and their evolution during the Campanian and Maastrichtian: Ph. D thesis. Washington DC: George Washington University.
- Buffetaut E. 1995. An ankylosaurid dinosaur from the Upper Cretaceous of Shandong (China) . *Geological Magazine* , 132: 683-692.
- Carpenter K 1999. Eggs , nests , and baby dinosaurs. Bloomington: Indiana University Press , 336.
- Chapman R E , Brett-Surman M K. 1991. Morphometric observations on hadrosaurid ornithopods// Carpenter K , Currie P J (eds.) . *Dinosaur systematics , approaches and perspectives*. Cambridge: Cambridge University Press , 163-177.
- Chinnery B J , Weishampel D B. 1998. *Montanoceratops cerorhynchus* (Dinosauria: Ceratopsia) and relationships among basal neoceratopsians. *Journal of Vertebrate Paleontology* , 18: 569-585.
- Danilov I G , Bolotsky Y L , Averianov A O , Donchenko I V. 2002. A new genus of lindholmemydid turtle (Testudines , Testudinoidea) from the Late Cretaceous of the Amur River Region , Russia. *Russian Journal of Herpetology* , 9: 155-68.
- Dasgupta P. 2003. Sediment gravity flow-the conceptual problems. *Earth Science Reviews* , 62: 265-281.
- Dong Z M , Zhou Z L , Wu S Y. 2003. Note on a hadrosaur footprint from Heilongjiang River area of China. *Vertebrata Palasiatica* , 41: 324-326.
- Godefroit P , Bolotsky Y L , Van Itterbeeck J. 2004a. *Amurosaurus riabinini* , a Late Cretaceous lambeosaurine dinosaur from Far Eastern Russia. *Acta Palaeontologica Polonica* , 49: 585-618.
- Godefroit P , Bolotsky Y L , Alifanov V. 2003. A remarkable hollow-crested hadrosaur from Russia: an Asian origin for lambeosaurines. *Comptes Rendus Palevol* , 2: 143-151.
- Godefroit P , Bolotsky Y L , Lauters P. 2009. A new *Gryposaurus* species (Dinosauria : Hadrosauridae) from the Maastrichtian (Late Cretaceous) of Far Eastern Russia . *Journal of Vertebrate Palaeontology* , 29: 106A.
- Godefroit P , Bolotsky Y L , Van Itterbeeck J. 2004b. *Amurosaurus riabinini* , a Late Cretaceous lambeosaurine dinosaur from Far Eastern Russia. *Acta Palaeontologica Polonica* , 49: 585-618.
- Godefroit P , Dong Z M , Bultynck P , et al. 1998. New *Bactrosaurus* (Dinosauria: Hadrosauridae) material from Iren Dabasu (Inner Mongolia , China) . *Bulletin de l'Institut royal des Sciences naturelles de Belgique , Sciences de la Terre* , 68 (Suppl.) : 3-70.
- Godefroit P , Hai S , Yu T , et al. 2008. New hadrosaurid dinosaurs from the uppermost Cretaceous of northeastern China. *Acta Palaeontologica Polonica* , 53: 47-74.
- Godefroit P , Zan S , Jin L. 2000. *Charonosaurus jiyainensis* n. g. , n. sp. , a lambeosaurine dinosaur from the Late Maastrichtian of northeastern China. *Comptes rendus de l'Académie des Sciences de Paris , Sciences de la Terre et des Planètes* , 330: 875-882.
- Godefroit P , Zan S , Jin L. 2001. The Maastrichtian (Late Cretaceous) lambeosaurine dinosaur *Charonosaurus jiyainensis* from north-eastern China. *Bulletin de l'Institut royal des Sciences naturelles de Belgique , Sciences de la Terre* , 71: 119-168.
- Hai S L. 2004. The dinosaur mass graves found in the Wulaga Region , Heilongjiang Province// Dong W (ed.) . *Proceedings of the Ninth Annual Symposium of the Chinese Society of Vertebrate Paleontology*. Beijing: China Ocean Press , 9-16.
- Horner J R. 1990. Evidence of diphyletic origination of the hadrosaurian (Reptilia: Ornithischia) dinosaurs//Carpenter K , Currie P J. (eds.) . *Dinosaur systematics , approaches and perspectives*. Cambridge: Cambridge Uni-

- versity Press , 179-187.
- Horner J R. 1992. Cranial morphology of *Prosaurolophus* (Ornithischia: Hadrosauridae) with description of two new hadrosaurid species and an evaluation of hadrosaurid phylogenetical relationships. *Museum of the Rockies Occasional Paper* , **2**: 1-119.
- Horner J R , Schmitt J G , Jackson F , et al. 2001. Bones and rocks of the Upper Cretaceous Two Medicine-Judith River clastic wedge complex , Montana// Hill C L. (ed.) . Society of Vertebrate Paleontology 61th annual meeting: Mesozoic and Cenozoic Paleontology in the Western Plains and Rocky Mountains. *Museum of the Rockies Occasional Paper* , **3**: 1-14.
- Horner J R , Weishampel D B , Forster C A. 2004. Hadrosauridae//Weishampel D B , Dodson P , Osmólska H (eds.) . The Dinosauria. Berkeley: University of California Press , 438-463.
- Iverson R M. 1997. The physics of debris flows. *Review of Geophysics* , **35**: 245-296.
- Jerzykiewicz T , Russell D A. 1991. Late Mesozoic stratigraphy and vertebrates of the Gobi Basin. *Cretaceous Research* , **12**: 345-377.
- Johnson K R. 2002. Megaflora of the Hell Creek and Fort Union Formations in the western Dakotas: vegetational response to climate change , the Cretaceous-Tertiary boundary event , and rapid marine transgression//Hartman J H , Johnson K R , Nichols D J. (eds.) . The Hell Creek Formation and the Cretaceous-Tertiary boundary in the northern Great Plains: an integrated continental record of the end of the Cretaceous. *Geological Society of America , Special Paper* , **361**: 329-391.
- Kirillova G L. 2003. Late Mesozoic-Cenozoic sedimentary basins of active continental margin of Southeast Russia: paleogeography , tectonics , and coal-oil-gas presence. *Marine and Petroleum Geology* , **20**: 385-397.
- Koster E H. 1987. Vertebrate taphonomy applied to the analysis of ancient fluvial systems// Ethridge F G , Flores R M , Harvey M D. (eds.) . Recent developments in fluvial sedimentology (Contributions from the Third International Fluvial Sedimentology Conference) . SEPM Special Publication , **39**: 159-168.
- Lauters P , Bolotsky Y L , Van Itterbeeck J , et al. 2008. Taphonomy and age profile of a latest Cretaceous dinosaur bonebed in Far Eastern Russia. *Palaios* , **23**: 153-162.
- Lehman T M. 1987. Late Maastrichtian palaeoenvironments and dinosaur biogeography in the western interior of North America. *Palaeogeography , Palaeoclimatology , Palaeoecology* , **60**: 189-217.
- Loope D B , Dingus L , Swisher C C I , et al. 1998. Life and death in a late Cretaceous dune field , Nemegt Basin , Mongolia. *Geology* , **26**: 27-30.
- Loope D B , Mason J A , Dingus L. 1999. Lethal landslides from eolian dunes. *Journal of Geology* , **107**: 707-713.
- Lull R S , Wright N E. 1942. Hadrosaurian dinosaurs of North America. *Geological Society of America Special Papers* , **40**: 1-242.
- Mack G H , James C W. 1994. Paleoclimate and the global distribution of paleosols. *Journal of Geology* , **102**: 360-366.
- Mack G H , James C W , Monger C H. 1993. Classification of paleosols. *Geological Society of America Bulletin* , **105**: 129-136.
- Markevitch V S , Bugdaeva Y V. 1997. Flora and correlation of layers with dinosaur fossil remains in Russia's Far East. *Tikhookeanskaya Geologia* , **16**: 114-124.
- Markevich V S , Bugdaeva E V. 2001a. Chapter 5: Correlation of the Upper Cretaceous and Palaeogene plant-bearing deposits of the Russian Far East//Bugdaeva E V (ed.) . Flora and dinosaurs at the Cretaceous-Paleogene boundary of Zeya-Bureya Basin (IGCP project 434) . Vladivostok: Dalnauka , 79-96.
- Markevich V S , Bugdaeva E V. 2001b. The Maastrichtian flora and dinosaurs of the Russian Far East// Goodman D K , Clarke R T. (eds.) . Proceedings of the IX International Palynological Conference , Houston , Texas , USA , 1996. AASP Foundation , 139-148.
- Maryańska T. 1977. Ankylosauridae (Dinosauria) from Mongolia. *Palaeontologica Polonica* , **30**: 85-151.
- Maryańska T , Osmólska H. 1979. Aspects of hadrosaurian cranial anatomy. *Lethaia* , **12**: 265-273.
- Maryańska T , Osmólska H. 1981. Cranial anatomy of *Saurolophus angustirostris* with comments on the Asian Hadrosauridae (Dinosauria) . *Palaeontologica Polonica* , **42**: 5-24.
- Moiseenko V G , Sorokin A P , Bolotsky Y L. 1997. Fossil reptiles of the Amur Region. Khabarovsk: Amur KNII FEBRAS , 1-53.
- Molnar R E , Kurzanov S M , Dong Z M. 1990. Carnosauria// Weishampel D B , Dodson P , Osmólska H. (eds.) . The Dinosauria. Berkeley: University of California Press , 169-209.
- Norell M A. 1992. Taxic origin and temporal diversity: the effect of phylogeny// Novacek M , Wheelers Q. (eds.) .

- Extinction and Phylogeny*. New York: Columbia University Press , 89-118.
- Retallack G J. 1988. Field recognition of paleosols. *Geological Society of America Special Paper* , **216**: 1-20.
- Riabinin A N. 1914. Report on a dinosaur from Transbaikalia. *Trudy Muzeo Petra Velikogo* , **8**: 133-140.
- Riabinin A N. 1925. A mounted skeleton of the gigantic reptile *Trachodon amurense* nov. sp. *Izvestija Geologicheskogo Komiteta* , **44**: 1-12
- Riabinin A N. 1930a. *Manschurosaurus amurensis* nov. gen. nov. sp. , a hadrosaurian dinosaur from the Upper Cretaceous of Amur River. *Mémoires de la Société paléontologique de Russie* , **2**: 1-36.
- Riabinin A N. 1930b. On the age and fauna of the dinosaur beds on the Amur River. *Mémoires de la Société Russe de Minéralogie* , série 2 , **59**: 41-51.
- Rich T H , Vickers-Rich P , Fernandez M , et al. 1999. A probable hadrosaur from Seymour Island , Antarctic Peninsula//Toshimida Y , Rich T H , Vickers-Rich P. (eds.) . Proceedings of the second Gondwanan dinosaur symposium. National Science Museum Monograph , **15**: 211-218.
- Rogers R R. 2005. Fine-grained debris flows and extraordinary vertebrate burials in the Late Cretaceous of Madagascar. *Geology* , **33**: 297-300.
- Rozhdestvensky A K. 1957. On the Upper Cretaceous dinosaur localities of the Amur River. *Vertebrata Palasiatica* , **1**: 285-291.
- Rozhdestvensky A K. 1977. The study of dinosaurs in China. *Journal of the Palaeontological Society of India* , **20**: 102-119.
- Russell D A. 1993. The role of Central Asia in dinosaurian biogeography. *Canadian Journal of Earth Sciences* , **30**: 2002-2012.
- Russell D A , Dong Z -M. 1993. A nearly complete skeleton of a new troodontid dinosaur from the Early Cretaceous of the Ordos Basin , Inner Mongolia , People's Republic of China. *Canadian Journal of Earth Sciences* **30**: 2163-2173.
- Russell D A , Manabe M. 2002. Synopsis of the Hell Creek (uppermost Cretaceous) dinosaur assemblage// Hartman J H , Johnson K R , Nichols D J. (eds.) . The Hell Creek Formation and the Cretaceous-Tertiary boundary in the northern Great Plains: an integrated continental record of the end of the Cretaceous. *Geological Society of America , Special Paper* , **361**: 169-176.
- Sereno P C. 1998. A rationale for phylogenetic definitions , with application to the higher-level taxonomy of Dinosauria. *Neues Jahrbuch für Geologie und Paläontologie , Abhandlungen* , **210**: 41-83.
- Soil Survey Staff. 1999. Soil Taxonomy (second edition) . US Department of Agriculture Handbook , 436. Washington D. C. : Printing Office , 1-871.
- Sullivan R M , Williamson T E. 1999. A new skull of *Parasaurolophus* (Dinosauria: Hadrosauridae) from the Kirkland Formation of New Mexico and a revision of the genus. *New Mexico Museum of Natural History and Science* , **15**: 1-52.
- Sun G , Akhmetiev M A , Dong Z M , et al. 2002. In search of the Cretaceous-Tertiary boundary in the Heilongjiang River Area of China. *Journal of Geoscientific Research in North-east Asia* , **5**: 105-113.
- Svendsen J , Stollhofen H , Crapf C B E , et al. 2003. Mass and hyperconcentrated flow deposits record dune damming and catastrophic breakthrough of ephemeral rivers , Skeleton Coast Erg , Namibia. *Sedimentary Geology* , **160**: 7-31.
- Swofford D L. 2000. Phylogenetic Analysis Using Parsimony (and other methods) . Version 4.0b10. Sunderland , Massachusetts: Sinauer Associates.
- Tumanova T A , Bolotsky Y L , Alifanov V R. 2004. The first finds of armored dinosaurs in the Upper Cretaceous of Russia (Amur Region) . *Paleontologicheskii Zhurnal* , **38**: 73-77.
- Vallance J W , Cunico M L , Schilling S P. 2003. Debris-flow hazards caused by hydrologic events at Mount Rainier , Washington. U. S. Geological Survey Open-file Report , 303-368: 1-4.
- Van Itterbeeck J , Bolotsky Y L , Bultynck P , et al. 2005. Stratigraphy , sedimentology and palaeoecology of the dinosaur-bearing Kundur section (Zeya-Bureya Basin , Amur Region , Far Eastern Russia) . *Geological Magazine* , **142**: 735-750.
- Weishampel D B. 1981. Acoustic analyses of potential vocalization in lambeosaurines dinosaurs (Reptilia: Ornithischia) . *Paleobiology* , **7**: 252-261.
- Wu W , Godefroit P , Han J. 2010. A hadrosaurine dentary from the Upper Cretaceous of Jiayin , Heilongjiang. *Global Geology* , **29**: 1-5.
- Xing Y L , Yu T X , Dong H M. 1994. The dinosaur fossil locality in Jiayin County of Heilongjiang Province and its research history. *Heilongjiang Geology* , **5**: 17-26.
- Xu X , Norell M A , Kwang X , et al. 2004. Basal tyrannosauroids from China and evidence for protofeathers in tyrannosauroids. *Nature* , **431**: 680-684.
- Yang D S. 1987. Observations on the palaeogeography and en-

- vironment of the Late Cretaceous titanosaur-hadrosaur fauna at Jiayin in Heilongjiang Province. *Nature Research of Heilongjiang Province* , 1987: 11-18.
- Yang D S , Wei Z Y , Li W R. 1986. Preliminary note on some hadrosaurs from the Cretaceous of Jiayin , Heilongjiang. *Nature Research of Heilongjiang Province* , 1986: 1-10.
- You H L , Luo Z X , Shubin N H , et al. 2003. The earliest-known duck-billed dinosaur from deposits of late Early Cretaceous age in northwest China and hadrosaur evolution. *Cretaceous Research* , **24**: 347-355.
- Young C C. 1958. The dinosaurian remains of Laiyang , Shantung. *Palaeontologia Sinica , series C* , **16**: 1-138.
- Zaleha M J , Weisemann S A. 2005. Hyperconcentrated flows and gastroliths: sedimentology of diamictites and wackes of the upper Cloverly Formation , Lower Cretaceous , Wyoming , U. S. A. *Journal of Sedimentary Research* , **75**: 43-54.

APPENDIX 1

Characters and character states used for the phylogenetic analysis of Hadrosauridae. Compiled from Godefroit et al. (1998 , 2001 , 2004a , b , 2008) , Bolotsky and Godefroit (2004) , and Horner et al. (2004) .

1. Parietal participating in the occipital aspect of the skull (0) , or completely excluded from the occiput (1) .
2. Ratio length / minimal width of the parietal >2 (0) , or <2 (1) .
3. Parietal sagittal crest relatively short , less than $2/3$ the length of the parietal (0) , or relatively long , more than $2/3$ the length of the parietal (1) . Contra Horner et al. , 2004.
4. Midline ridge of parietal straight to slightly downwarped along length (0) , or strongly downwarped to below the level of the postorbital – squamosal bar (1) .
5. Frontal participating in the orbital rim (0) , or excluded by postorbital – prefrontal joint (1) .
6. Hollow supracranial crest absent (0) , or developed (1) .
7. Frontal relatively long , with a 'caudal length / maximal width' ratio > 0.75 (0) , very shortened frontal , with a 'caudal length / maximal width' <0.6 (1) , or secondary elongation resulting of the backward extension of the frontal platform (2) . Character treated as ordered.
8. Deeply excavated frontal platform absent (0) , occupying the rostral part of the frontal in adult (1) , or extending above the rostral portion of the supratemporal fenestra (2) . Character treated as ordered.
9. Premaxillae narrow , expanded laterally less than two times width at post – oral constriction , margin oriented nearly vertically (0) , or expanded transversely to more than two times postoral constriction , margin flared laterally into a more horizontal orientation (1) .
10. Premaxillary reflected rim absent (0) , deflected at antero-lateral corner and posteriorly reflected (1) , reflected along entire rim and narrow (2) , reflected along entire rim , but thickened at anteroventral corner (3) . Character treated as ordered.
11. Premaxillary foramen present (0) , or absent (1) .
12. Premaxillary , auxiliary narial fossa absent (0) , or present (1) .
13. Posterior premaxillary process short , not meeting the lateral premaxillary process posterior to external naris (0) , or posterior premaxillary process long , meeting the lateral premaxillary process behind the external naris to exclude the nasal , nasal passage enclosed ventrally by folded , divided premaxillae (1) .
14. Lateral premaxillary process stopping at the level of the lacrimar (0) , or extending further backward above the skull roof (1) . Character treated as unordered.
15. External naris / basal skull length ratio <0.2 (0) , or >0.3 (1) .
16. Posteriormost apex of external naris formed entirely by nasal (0) , formed by nasal (dorsally) and premaxilla (ventrally) (1) , or formed entirely by premaxilla (2) . Character treated as unordered.
17. Circumnarial depression absent (0) , light depression incised into nasal and premaxilla (1) , or marked by a well – developed ridge and sometimes invagined (2) . Character treated as ordered.
18. Nasal restricted to area rostral to braincase , cavum nasi small (0) , or nasal retracted caudally to lie over braincase in adults resulting in convoluted , complex narial passage , cavum nasi enlarged (1) .
19. Nasal does not participate in a hollow crest (0) , participates in a small part of the hollow crest and is excluded from the caudodorsal border of the crest (1) , participates in half of the crest or more and forms the caudodorsal aspect of the crest (2) , or forms the entire crest (3 , autapomorphic for Tsintaosaurus) . Character treated as unordered.
20. Solid supracranial crest absent (0) , present but not excavated by the caudal circumnarial fossa (1) , present and excavated laterally by the circumnarial fossa (2) . Character treated as unordered.
21. Supraorbital free (0) , or fused to the prefrontal (1) .
22. Caudal portion of the prefrontal oriented horizontally (0) , or participating in the lateroventral border of the hollow crest (1) .
23. Median ramus of squamosal lower than paroccipital process (0) , or higher than paroccipital process (1) .
24. Squamosal prequadratic process strikingly longer than rostrocaudal width of quadrate cotylus (0) , or short , only slightly longer than rostrocaudal width of quadrate cotylus (1) .
25. Posterior surface of supraoccipital nearly vertical (0) , or steeply inclined forwardly at an angle of about 45° (1) .
26. Supraoccipital / exoccipital shelf limited (0) , or very extended (1) above the foramen magnum.
27. Postorbital pouch absent (0) , or well – developed (1) .
28. Dorsal surface of postorbital flat (0) , or thickened to form a dorsal promontorium (1) .

29. Rostral process of the jugal tapering in lateral view to fit between maxilla and lacrimal (0) , or dorso - ventrally expanded (1) .
30. Rostral process of the jugal angular and slightly asymmetrical in lateral view (0) , rounded and symmetrically very expanded (1) , isosceles - triangle - shaped (2) , or asymmetrically strongly upturned (3) . Character treated as unordered.
31. Jugal flange slightly developed , dorsoventral depth of jugal from ventral border of infratemporal fenestra to ventral edge of flange approximately equal to minimum dorsoventral depth of rostral segment of jugal between rostral and postorbital process (0) , dorsoventral depth of jugal from ventral border of infratemporal fenestra to ventral edge of flange less than twice minimum dorsoventral depth of rostral segment of jugal between rostral and postorbital process (1) , or strongly projected ventrally into semicircular boss , dorsoventral depth of jugal from ventral border of infratemporal fenestra to ventral edge of flange twice or nearly twice minimum dorsoventral depth of rostral segment of jugal between rostral and postorbital process (2) . Character treated as ordered.
32. Apex of maxilla caudal to centre (short caudal portion of maxilla) (0) , or at or rostral to center (long and robust caudal portion of maxilla) (1) .
33. Maxillary foramen on rostrolateral maxilla (0) , or on dorsal maxilla along maxilla - premaxilla suture.
34. Ectopterygoid ridge faintly developed and inclined caudally (0) , or strongly developed and nearly horizontal (1) .
35. Rostromedial process developed on the maxilla (0) , or wide sloping maxillary shelf (1) .
36. Paraquadratic foramen present (0) , or absent (1) .
37. Distal head of quadrate transversely expanded (0) , or dominated by a large hemispheric lateral condyle (1) .
38. Diastema between first dentary tooth and predentary short , no more than width of 4 or 5 teeth (0) , moderate , equal to approximately 1/5 to 1/4 of tooth row (1) , long , more than 1/3 of tooth row , but less than 1/2 (2) , or extremely long , more than 1/2 of tooth row (3) . Character treated as ordered.
39. Coronoid process sub - vertical (0) , or inclined rostrally (1) .
40. Rostral mediolateral width of predentary less than or equal to rostrocaudal length of lateral process (0) , rostral mediolateral width greater than or equal to rostrocaudal length of lateral process (1) , or rostral mediolateral width greater twice rostrocaudal length of lateral process (2) . Character treated as ordered.
41. Number of tooth positions in dentary tooth row (adult specimens) : 30 or less (0) , 34 - 40 (1) , 42 - 45 (2) , 47 or more (3) . Character treated as ordered.
42. Dentary crowns broad with a dominant ridge and secondary ridges (0) , or miniaturised with or without faint secondary ridges (1) .
43. Median carina of dentary teeth straight , (0) or sinuous (1) .
44. A maximum of 7 (0) , or a minimum of 8 (1) sacral vertebrae.
45. Posterior dorsal and sacral neural spines relatively short , less than 3 times centrum height (0) , or elongate , more than three times centrum height (1) .
46. Coracoid hook small and pointed ventrally (0) , or prominent and pointed cranioventrally (1) .
47. Biceps tubercle on coracoid small (0) , or large and laterally projecting (1) .
48. Proximal plate of sternal shorter than distal handle (0) , or proximal plate longer than distal handle (1) .
49. Deltpectoral crest of the humerus moderately (0) , or strongly developed , extending down below midshaft (1) .
50. Antitrochanter of ilium absent or poorly developed (0) , or prominent (1) .
51. Ischial peduncle of ilium as a single large knob (0) , or formed by two small protrusions separated by a shallow depression (1) .
52. Postacetabular process of ilium tapers caudally to nearly a point , wide brevis shelf (0) , or postacetabular process sub - rectangular , no brevis shelf (1) .
53. Distal end of ischium forming a moderately expanded knob (0) , hypertrophied and footed (1) , or tapering distally (2) . Character treated as unordered.
54. Distal head of fibula moderately expanded into the shape of a ball (0) , or greatly expanded and club - shaped (1) .
55. Cranial ascending process of astragalus laterally skewed (0) , or equilateral in shape (1) .
56. Plantar keels on unguals absent (0) , or present (1) .

APPENDIX 2

Character-taxon matrix for phylogenetic analysis of Hadrosauridae.

	1 - 5	6 - 10	11 - 15	16 - 20	21 - 25	26 - 30	31 - 35	36 - 40	41 - 45	46 - 50	51 - 55	56
<i>Bactrosaurus</i>	00000	00000	00000	00000	00000	00000	00000	00000	00000	00000	00000	0
<i>Aralosaurus</i>	? 1? 00	100??	?????	?? 0? 0	101? 1	0001?	? 0111	11???	?????	?????	?????	?
<i>Tsintaosaurus</i>	01001	10010	?? 0??	?? 030	11001	00011	10111	11111	11111	11111	11100	0
<i>Jaxartosaurus</i>	01001	101??	?????	???? 0	11001	0001?	?????	?????	?????	?????	?????	?
<i>Amurosaurus</i>	01011	101??	?????	???? 0	11101	00011	10111	1111?	111??	11111	11100	0
<i>Corythosaurus</i>	01011	11110	10110	20120	11101	00011	10111	11111	21111	11111	11100	0
<i>Hypacrosaurus</i>	01011	11110	10110	20120	11101	00011	10111	11111	21111	11111	11100	0
<i>Olorotitan</i>	01011	11110	10110	20120	11?? 1	0?? 11	10111	1111?	21111	11111	11100	0
<i>Lambeosaurus</i>	01011	11110	10110	20110	11101	00011	10111	11111	21111	11111	11100	0
<i>Parasaurolophus</i>	11011	12210	10100	20110	11101	00111	10111	11111	21111	11111	11111	0
<i>Charonosaurus</i>	11011	112??	?????	???? 0	11101	00111	10111	1111?	? 1111	11111	11111	0
<i>Sahaliyana</i>	? 10? 1	111??	?????	???? 0	11?? 1	0?? 11	101? 1	1111?	211??	?? 111	111??	?
<i>Wulagasaurus</i>	? 00??	?????	?????	?????	???? 1	0????	? 1? 1?	?? 11?	?????	?? 00?	?? 2??	?
<i>Maiasaura</i>	00100	00011	01000	01001	10011	00012	21110	11112	21010	11001	11200	1
<i>Brachylophosaurus</i>	00100	00011	01001	01001	10011	00012	21110	11212	21010	11001	11200	1
<i>Gryposaurus</i>	00100	00012	01001	01000	10001	10013	11110	11111	21010	11001	11200	0
<i>Kerberosaurus</i>	001? 1	000??	?????	? 2?? 0	10001	1? 013	11110	11???	2? 0??	11???	?????	0
<i>Saurolophus</i>	00101	00012	01001	12002	10001	10013	11110	11211	31? 10	11001	11200	?
<i>Prosaurolophus</i>	00101	00012	01001	12002	10001	10013	11110	11211	21010	11001	11200	0
<i>Anatotitan</i>	00100	00013	01001	12000	10001	11013	11110	11311	31010	11001	11200	0
<i>Edmontosaurus</i>	00100	00013	01001	12000	10001	11013	11110	11311	31010	11001	11200	0

APPENDIX 3

List of apomorphies for all ingroup taxa. Letters indicate nodes designated in Fig. 19. For multistate characters, the number between brackets refers to the character state (see Appendix 1). Character are followed by an 'a', when supported only by ACCTRAN or fast optimisation, and by a 'd', when supported only by DELTRAN, or slow optimisation. bs: bootstrap value.

A (Hadrosauridae): 9, 21, 25, 29, 31(1), 33, 34, 36, 37, 38(1), 39, 40(1), 41(1), 42, 44, 46, 47, 50, 51, 52.

B (Lambeosaurinae; bs = 93): 2, 6, 11a, 16(2) a, 19(1) a, 30(1) a, 35, 43a, 45a, 48a, 49a, 53(1) a.

C (bs = 79): 5, 22, 30(1) d, 43d, 45d, 48d, 49d, 53(1) d.

D (bs = 54): 8(1), 13a, 18a.

E (bs = 59): 4, 23.

F (bs = 70): 7(1), 41(2), 11d, 13d, 16(2) d, 18d, 19(1) d.

G (parasauroloph clade: Chapman and Brett - Surman 1990; bs = 95): 1, 28, 54, 55.

H (corythosaur clade: Chapman and Brett - Surman 1990; bs = 82): 14.

I (bs = 63): 19(2) .

J (Hadrosaurinae; bs = 76): 10(1) a, 12a, 15a, 17(1) a, 30(2) a, 32, 41(2) a, 53(2) .

K (bs = 75): 3, 10d, 12d, 17(1) d, 41(2) d.

L (bs = 88): 20(1), 24, 30(2), 31(2), 40(2), 56.

M (bs = 72): 10(2), 15d, 26, 30(3), 38(2) a.

N (bs = 78): 16(1), 17(2), 38(2) .

O (bs = 54): 5.

P (bs = 58): 20(2) .

Q (bs = 95): 10(3), 27, 38(3), 41(3) .